

DOCUMENT RESUME

ED 256 620

SE 045 554

AUTHOR Elfner, Lynn Edward, Ed.
 TITLE Ohio Science Workbook: ENERGY. 1984-85 Edition.
 INSTITUTION Ohio Academy of Science, Columbus.
 SPONS AGENCY Ohio State Dept. of Development, Columbus. Office of
 Energy Conservation.
 PUB DATE 9 Feb 85
 NOTE 15p.
 PUB TYPE Reference Materials - General (130)

EDRS PRICE MF01/PC03 Plus Postage.
 DESCRIPTORS Elementary School Science; *Energy; *Energy
 Education; Industry; Information Sources;
 Intermediate Grades; Resource Materials; Science
 Education; *Science Experiments; Secondary Education;
 *Secondary School Science; *Student Projects; Student
 Research
 IDENTIFIERS *Ohio

ABSTRACT

This resource guide is designed to: (1) stimulate development of student energy research projects; (2) expose students to research problems important to Ohio's science- and engineering-related industries; (3) strengthen the working relationship between science, mathematics, and English teachers in promoting technical communication skills; (4) engage Ohio's corporations in a partnership with the Ohio Academy of Science and state government to provide curriculum materials; and (5) help students develop and sharpen their library research skills, particularly those in the area of energy research. The guide is divided into four sections. The first section (taken from the "Energy-Environment Sourcebook," by John Fowler) examines: the nature and role of energy; force, work, energy, and power; heat and heat engines; and generation, transmission, and distribution of energy. The second section presents suggested projects to stimulate student research on energy. These projects were submitted by individuals or industries and include background information, a discussion of the problem to be solved, recommended methodology, and references. The third section discusses how to find energy information in the library. The fourth and last section provides additional references and sources of information. (JN)

 * Reproductions supplied by EDRS are the best that can be made *
 * from the original document. *

ED256620

SE 045 554

U.S. DEPARTMENT OF EDUCATION
NATIONAL INSTITUTE OF EDUCATION
EDUCATIONAL RESOURCES INFORMATION
CENTER (ERIC)

✓ The document has been reproduced as
received from the person or organization
originating it.
Minor changes have been made to improve
reproduction quality.

• Points of view or opinions stated in this docu-
ment do not necessarily represent official NIE
position or policy.

"PERMISSION TO REPRODUCE THIS
MATERIAL HAS BEEN GRANTED BY

Lynn E. Elfner

TO THE EDUCATIONAL RESOURCES
INFORMATION CENTER (ERIC)."

Ohio Science Workbook: ENERGY

1984-85 Edition

Edited by

Lynn Edward Elfner

**Production of this publication was made possible in part
by a grant to The Ohio Academy of Science
from The Ohio Department of Development,
Office of Energy Conservation.**

**The Ohio Academy of Science
445 King Avenue
Columbus, OH 43201
Phone (614) 424-6045**

Copyright 1985 by The Ohio Academy of Science.

ALL RIGHTS RESERVED. *Except for non-commercial educational use or literary review, no part of this book may be reproduced or utilized in any form or by any means, electronic or mechanical, including photocopying, recording, or by any information storage or retrieval system, without written permission from the Publisher. Address requests to:

The Ohio Academy of Science
445 King Avenue
Columbus, OH 43201

Publication date: February 28, 1985

*Credit line should read: Reproduced for non-commercial educational use only. Copyright 1985 by The Ohio Academy of Science.

CONTENTS

FOREWORD AND ACKNOWLEDGMENTS.....	4
ENERGY BASICS.....	5
SUGGESTED STUDENT ENERGY RESEARCH PROJECTS.....	29
HOW TO FIND ENERGY INFORMATION IN YOUR LIBRARY.....	56
ADDITIONAL REFERENCES AND SOURCES OF INFORMATION.....	59

FOREWORD AND ACKNOWLEDGMENTS

Originated in 1964 by the Ohio R & D Foundation and administered for more than 15 years by The Ohio Academy of Science, the Ohio Science Workbook program has been revived for the 1984-85 school year by a grant to The Ohio Academy of Science from the Ohio Department of Development, Office of Energy Conservation. The Ohio Science Workbook: ENERGY is a resource guide for teachers which will meet several objectives:

1. to stimulate the development of student energy research projects;
2. to expose students to research problems important to Ohio's science and engineering related industries;
3. to strengthen the working relationship between science, mathematics, and English teachers in the promotion of technical communication skills;
4. to engage Ohio's corporations in a partnership with the Academy and State Government to provide curriculum materials; and
5. to help students develop and sharpen their library research skills, particularly in the area of energy research.

We would like to thank

The Ohio Department of Development
Office of Energy Conservation

for financial support necessary to produce this workbook. But even with financial support this workbook would not have been possible without the following who generated the ideas for projects:

Procter and Gamble Company
Owens-Illinois, Inc.
The Standard Oil Company of Ohio
Owens/Corning Fiberglas
American Electric Power Service Corporation
Borden, Inc.
Westinghouse Electric Corporation
National Rural Electric Cooperative Association
James McAleese

We also want to thank members of the Junior Academy Council and others who have provided technical reviews of this publication.

And last we acknowledge the work of Dr. John Fowler of the National Science Teachers Association whose chapters on energy basics originally appeared in Energy-Environment Source Book published by NSTA in 1975.

ENERGY BASICS

The next 23 pages are taken from **Energy-Environment Sourcebook** by John M. Fowler.

- **Energy: What It Is, What It Does** (p. 103-109) p. 6
- **Force, Work, Energy and Power** (p. 239-242) p. 13
- **Heat and Heat Engines** (p. 245-249) p. 17
- **Generation, Transmission, and Distribution of Energy** (p. 253-259) p. 22

Energy: What It Is, What It Does

"A rose is a rose is a rose" is a definition of a rose only to someone who has seen these flowers. We can do little better in talking about energy; we can only define it to someone who already has some idea of what it is.

There are, of course, scientific statements we could make about energy, about its relation to such other scientific concepts as force, work, and power, or about the laws that govern it. We will, however, take a bare minimum of words from the vocabulary of science, only those needed to understand the twin crises of energy and environment. We will begin the story with "energy is energy."

Energy Is

It is not possible to be unaware of energy; it forces itself to our attention from all parts of our life. Newspapers and magazines carry articles about the Energy Crisis and the ways we are moving to meet it. Television carries advertisements about oil exploration and documentaries about strip mining on the Western Plains. There is an image of energy in the smoke from a power plant or a steel mill, in the transmission lines along the road or the oil truck on it. There is energy in the electric toaster and in its hot buttered toast. Energy is defined to us in all these ways and many more.

Whenever we have heat, or light (or the other forms of radiation: radio, x-rays, ultraviolet, etc.), or motion, we have energy in action. Whenever we have something, such as a lump of coal, a battery, or a piece of uranium, that can ultimately provide us with heat, light, or motion, we know that energy is stored in that something.

When faced with such diversity, our first step toward understanding is to set up categories, to reduce the diversity of form that energy shows by classifying it. We have already suggested the first classification. Energy in the form of motion, heat, or light is called *kinetic energy*. The energy stored in bread, gasoline, or batteries, in the nucleus of the uranium atom, or in any of its other clever hiding places, is *potential energy*. Kinetic energy is energy in transit, energy on the move. We use it in this form. Potential energy is *stored energy* and it is in this form that we dig it from mines, pump it from wells, ship it, and stockpile it. The whole story of energy is found in the description of these two forms, and in the conversions between them.

To use energy it must be in the kinetic form. We use energy because we want to *do* something to matter: move it, illuminate it, or warm it. A moving car has kinetic energy. The electrons flowing through the toaster's heating element and the photons of light coming to us from the sun have their energy in kinetic form.

We store energy in the potential form. It is, of course, possible to store kinetic energy; the flywheel of an engine stores kinetic energy in its rotating mass and kinetic

energy is stored in the rotation of the moon about the earth. We can, also, store heat energy in Thermos bottles. Light energy is almost impossible to store. Kinetic energy storage, however, is quite different from potential energy storage. It is temporary; we trap or insulate kinetic energy, it is a caged tiger ready to run free.

Potential energy storage is more permanent. It is accomplished within the structure of matter. Energy is stored, for instance, in the carbon atom and released when that carbon atom is combined with an oxygen molecule in the chemical reaction we call burning. The product of this reaction is carbon dioxide, CO₂. The nucleus of the uranium atom stores energy that is released when that nucleus is split in two in the fission reaction. A simple way to store energy is to lift something away from the earth. Energy is stored when water is pumped to the top of a water tower, then converted to the kinetic energy of motion when the water is allowed to run through the pipes to its final destination. In general, to store energy we must move things around against the action of some force, lift a weight, force electrons into a battery or compress a spring, for instance.

The Energy Laws

From what we have said so far, it should be becoming clear that the story of energy is one of flow and change. Energy is not really like a flower, but like a chameleon; it has a basic identity but constantly changes form. It can be potential energy stored in coal, but when the coal is burned in a power plant furnace, it changes to a kinetic form, the heat energy of steam. When the steam is allowed to strike the blades of a turbine, some of this heat energy becomes the kinetic energy of motion of this engine. The turbine turns an electric generator and some of the same energy that was released from the coal becomes electric energy, the kinetic energy of the motion of electrons in wires. And still the flow doesn't end; electricity goes out through the wires to perform a great variety of tasks, from running the turntable of our stereo to making ice cubes in the refrigerator.

These changes of form are not free or arbitrary, they are governed by strict laws. The first of these is quite reassuring; it seems to say that there can't be an Energy Crisis. Called the Law of Conservation of Energy (or the First Law of Thermodynamics, if you want a fancy name) it states:

Energy can be neither created nor destroyed.

This says that once you have a certain amount of energy, the 200 Calories you get from eating a candy bar, for instance, it never disappears. It may become heat energy in your body, or power your muscles, or be used in the processes in your brain. It may be stored as fat. More likely, it does some of all these things all at once, but it always remains 200 Calories of energy.

This first law is good news. We can never run out of energy. Where then is the problem? The second law, which is named "The Second Law of Thermodynamics," but which we'll call "The Heat Tax," gives the bad news:

In any conversion of energy from one form to another some of it becomes unavailable for further use.

It becomes unavailable because it becomes heat and it is not possible to convert a given amount of heat energy completely back into another form. Said in another way, in any conversion or use of energy there is a "heat tax"; some of the energy becomes heat and is no longer usable. This unusable heat energy leaks away and gradually warms up the earth (and finally the universe). It is this second law that is behind the Energy Crisis.

It is also clear that this second law puts heat energy in a unique position. It is possible to convert all of a certain amount of mechanical energy to heat, by rubbing two sticks together or putting on the brakes of a car, for instance. It is possible to convert all the chemical energy of coal into heat energy by burning it. These conversions cannot go to completion in the other direction, however. In the language of science they are "irreversible." Heat energy stands at the end of a one-way street, all other energy forms ultimately can be converted into heat, but only a limited amount of heat energy is convertible back to other forms.

We are only skimming some interesting science with these statements. Why do we believe these laws? What is the nature of this strange energy we call heat? How can we convert heat energy to mechanical energy? We answer some of these questions more fully in Appendix 4. For now we must get on with our story and look at energy from the narrow perspective of man.

Energy, Work, and Power

So far we have defined energy by asking you to observe it around you as light, motion, or heat, or as the capacity to produce these conditions. There is another word, *work*, that is associated with energy. It is used to describe man's use of energy in mechanical form: transporting things, rearranging, or distorting them. We do work when we lift a weight, push a car, pull back a bowstring, or swing a golf club. Work, therefore, is the same as energy—it is mechanical energy in use.

Power: A second term associated with man's energy-consuming activities is power. We talk of the power of a car or a motor or a stereo amplifier. As we look deeper into this concept, we find that time is involved in its definition. Power is the rate of doing work, or, more generally, the rate at which energy is used. In mathematical terms, power is the amount of energy used (or work done) divided by the time it takes to do that work. In symbols

$$P \text{ (power)} = \frac{W \text{ (work)}}{T \text{ (time to do the work)}}$$

We also see from this that $W \text{ (work)} = P \text{ (power)} \times T \text{ (time)}$.

Work and power play different roles in our discussions. We use work terms to describe things that must be done and for which time is not important. It takes a

certain amount of work (or energy) to lift a box, melt an ice cube, or refine aluminum. Power enters when we are dealing with continuous input (or output) of work; with lightbulbs or automobiles, for instance.

When we buy gasoline, we are buying energy and, ultimately, work. We pay for the work to get the car from City A to City B. When we bought the car, however, we bought power. We paid for the horsepower of the engine which determines how fast it can burn the gasoline and thus how fast it can do the work, how quickly it can get us from City A to City B.

Units

We are defining energy by describing it. The final step in this definition is measurement, and to report a measurement we need units — feet, seconds, pounds are familiar ones.

There are many different units for work and power. They were defined for different purposes at different times. The "horsepower," for instance, an old unit, is the rate at which a horse can perform work for an extended time. The kilowatt, a newer electrical unit, is defined in terms of electric current and voltage. There is a similar range of choices for energy and work.

In Appendix 3 we define all of the commonly-used units of energy (work) and power. We also provide there the rules and numbers for converting from one unit to another. In this section we introduce and define only those units that will be in our basic vocabulary for this Source Book.

Since work and energy are interconvertible, a wide variety of choices of units is open to us. We will use the *Calorie*, with a capital C (in scientific terminology the kilocalorie), which originated as a unit of heat energy. It is the amount of work (or energy) necessary to raise the temperature of one kilogram (2.2 pounds) of water, 1°C, (degree centigrade, or *Celsius*, which is the preferred terminology). It is also the same unit we use to measure the energy value of food; the normal dietary intake is 2,000 to 3,000 Calories per day. Calories are based on the kilograms and degrees Celsius of the metric system, and since the United States is reluctantly, but inevitably converting to this universal system, it seems a reasonable choice.

The unit of power most frequently used in the Source Book is the electrical unit, the *kilowatt*, as electricity is becoming our most important form of power. A kilowatt (kw) is one thousand watts, about the amount of electric power needed to provide the heat for an electric toaster. The definition of the watt is developed in Technical Appendix 3. Since power is work divided by time, we can produce a work, or energy, unit, by multiplying a unit of power by time. Occasionally we use a unit derived in this way, the kilowatt-hour (kw-hr), to measure electric energy.

Numbers and Sizes

The other troublesome aspect of our quantitative descriptions of energy and power is that we have to deal with a broad range of numbers, from the 100 watts of the

lightbulb, for instance, to the approximately 400,000,000,000 watts (400 billion watts) that is the present total generating capacity of this country. We will work with millions of tons of coal, billions of barrels of oil, trillions and even quadrillions of Calories. To keep this terminology as simple as possible we abbreviate these numbers in the manner shown in Table A2-1 of Appendix 2; a million is M; a billion, 1,000,000,000, is B; a trillion, 1,000,000,000,000, is T; a quadrillion, 1,000,000,000,000,000, is Q, etc. We discuss these large numbers a bit more in Appendix 2.

In Tables 1-1 and 1-2 we show some details of this range of sizes. Table 1-1 shows some of the reference points on an energy scale that stretches from the incomprehensibly small energies involved in molecular events to the equally incomprehensibly large numbers that measure earth's daily income of solar energy. Table 1-2 presents similar reference points in a power range stretching from a hummingbird's power up through the SST and, finally, to a similar ultimate, the incoming solar power. It is often necessary to compare quantities whose growth takes them from the thousands to the billions, this leads us to the "semilogarithmic" presentation of data we will introduce in Chapter 4 and also discuss in Technical Appendix 2.

The Flow of Energy on Earth

With regard to food, mineral resources, air, and water, earth is a spaceship entirely on her own. She carries much of her energy with her, but, fortunately, there is a Mothership, sun, that beams in a fresh energy supply every day. Earth's energy resources, therefore, are a

mixture of stored, potential energy, and transient, kinetic energy. There are two basic questions to ask: What are the forms of energy available to us? What are their relative amounts? We will focus on the first of these questions in this chapter and leave the assessment of the resource size to Chapter 2.

Figure 1-1 gives the quantitative information that allows comparison of the various flows of energy (power) to and from earth. We also indicate the two depletable sources of energy, the fossil fuels and nuclear energy. The flow from Mothership sun dwarfs all others; at the top of the atmosphere, the earth receives 173 trillion kilowatts, 173 T kw, of power. For comparison, the total electric generating capacity of the world in 1968 (the last figure available) was about 900 M kw, only 1/200,000 of the power we receive from the sun.

Of course not all of the sun's energy is available to our purposes. As we see from Figure 1-1, 30 percent of this is immediately reflected by the atmosphere, and another 47 percent is absorbed by the atmosphere, the oceans, and the land, and then reradiated. All in all, about half of the total power reaches the ground. Most of the power that is not absorbed and then reradiated, 40 T kw, or 23 percent of the total, is used to evaporate water, providing the energy for the important water cycle of earth. The rest of the processes use less than one percent of the total. The impressive power of wind, waves, and ocean currents is not so impressive when measured against these totals; 370 B kw are used on the average in this way, 0.5 percent of the total. The power used to sustain life is, on this scale, miniscule; 40 B kw at the most, an almost negligible 0.04 percent of

TABLE 1-1
Some Representative Energy Data

	Calories
Energy in 1 Photon of Ultraviolet Light ($\lambda = 2250\text{\AA}$) ^(a)	21.2×10^{11}
Energy (gravitational) of 1 Pound of Mass 1 Mile Above Sea Level	2
Energy To Melt 1 Pound of Ice (at 0°C)	36
Energy To Evaporate 1 Pound of Water	245
Energy (chemical) Released by Exploding 1 Pound of TNT	520
Energy (chemical) Released by Burning 1 Pound of Wood	1,250
Energy (chemical) Released by Burning 1 Pound of Sugar	1,860
Energy (chemical) Released by Burning 1 Pound of Coal	3,300
Energy (chemical) Released by Burning 1 Pound of Gasoline	4,750
Energy Needed To Manufacture an Automobile ^(b)	5,200,000
Energy Needed To Send Apollo 17 To Moon ^(c)	1,420,000,000
Energy (nuclear) Released by Fusing 1 Pound of Deuterium	32,000,000,000
Energy (nuclear) Released by Fission of 1 Pound of U ²³⁵	137,000,000,000
Energy Equivalent of 1 Pound of Mass ($E=mc^2$)	9,800,000,000,000
U.S. Daily Energy Consumption (1970)	47,000,000,000,000
World Daily Energy Consumption (1970)	140,000,000,000,000
Energy Needed To Fill Lake Michigan ^(d)	400,000,000,000,000
Solar, Earth's Daily Total at Top of Atmosphere	3.8×10^{17}
World Supply of Recoverable Fossil Fuels ^(e)	5.0×10^{17}
Sun's Daily Output	7.8×10^{27}

^(a) λ = wavelength, \AA = angstrom, 10^{-10} meters.

^(b) R. Stephen Berry, "Recycling, Thermodynamics, and Environmental Thrift," Bulletin of the Atomic Scientist, May 1972.

^(c) Courtesy Marshall Space Flight Center.

^(d) 5.8×10^{12} kg, raised from 25°C to 100°C.

^(e) M. King Hubbert, "The Energy Resources of the Earth," Scientific American, 224, 61, September 1971.

the incoming energy. Even this small number is, however, 40 times as large as the total generating capacity of the world we quoted earlier.

Measured against this munificence, the nonsolar sources of energy seem puny. There are four. Some of the sun's energy has been stored as chemical potential energy in the fossil fuels—coal, oil, and natural gas. The estimated maximum size of the fossilized carbon is about 7,000 Q kilograms. At the 8 Calorie per kilogram of energy released in combustion, this would produce a total of 56,000 Q Calories, which (by the conversions of Calories to kw-hr of Table A3-2) is equivalent to 65 Q kw-hr. By burning all of the fossil carbon, formed over millions of years, we would produce only as much energy as the sun sends in during 15½ days. This value, 65 Q kw-hr, is, of course, an upper limit; it represents all of the fossil carbon and only a small fraction of that, a ten-thousandth or less, is actually available to us. In our burning and conversion we lose much of this energy. We will come back to this number in a later section.

More than 90 percent of the energy that powers our economy comes from burning fossil fuels. In addition to this chemical source of potential energy, there are three others that we show in Figure 1-1: geothermal energy (energy whose source is the earth's molten interior), the energy of the tides, and the new source, nuclear energy. The total power leaking from the earth's interior is only 32 B kw, one five-thousandth of the incoming solar energy, while tides and tidal currents provide only 3 B kw, one fifty-thousandth of the solar input.

TABLE 1-2
Some Representative Power Data

	Kilowatts
Bird Flying (hummingbird) [a]	0.007
Human at Rest	0.017
Dog Running Fast [a]	0.08
Fish Swimming (dolphin) [a]	0.2 ¹
Human Walking at 2 mph	0.23
Horse Working Steadily (one horsepower)	0.75
Human Running	0.93-1.2
Human (top athletic performance) [a]	1.7
U.S. Per Capita Power (1973)	11.9
Automobile at 60 mph [b]	29.3
Automobile at Top Acceleration [c]	100
Bus [d]	150
Commuter Train [d]	3,000
707 Jet [d]	21,000
SST [d]	180,000
Fossil Fuel Consumption in Urban Area (per square mile) [e]	825,000
U.S. Electric Power Consumption (1973 average)	7,350,000
World Total Power Consumption (1970)	6,000,000,000
Solar Power Involved in Photosynthesis	40,000,000,000
Incoming Solar Power (total)	173,000,000,000,000

[a] "Locomotion: Energy Cost of Swimming, Flying, Running," Schmidt-Nielsen, *Science* 177, 222 (1972).

[b] A 5,000-pound car uses 39 H.P. under average conditions at 60 mph, Thomas C. Austin, EPA, private communication.

[c] A 4,735-pound automobile accelerates to 60 mph in 11 seconds.

[d] "Lost Power," *Environment*, April 1972.

[e] The 1970 National Power Survey, Federal Power Commission.

The primary sources of energy available to us on earth are, therefore, five: solar, chemical, geothermal, tidal, and nuclear. Three of these — solar, geothermal, and tidal — are in kinetic form, the other two — the chemical energy of the fossil fuels and nuclear energy — are stored potential forms. We will briefly discuss each of these in the sections that follow.

Solar energy: Solar energy is kinetic energy. It is, more precisely, radiant energy, much of it in the form of visible light. What arrives at the top of the atmosphere is about half ultraviolet radiation — the invisible blue radiation that gives us sunburn — and half visible light. When solar radiation enters the atmosphere, several things can happen. It can be reflected, and as we see from Figure 1-1, 30 percent of this energy is immediately reflected back into space. It can be absorbed by the molecules of the atmosphere, the ocean, or the land surface and increase their energy. This added energy heats them, some of it is reradiated away and lost, some goes into the kinetic energy of their motion. The solar energy that gets to the earth's surface is the important part for us. It heats the land and the ocean and is the source of energy for the great currents, the winds and the waves, in air and ocean.

Man gets some of his energy from the motion of wind and water. The sun's energy evaporates water which rises and is carried on the winds. If it falls on the mountains, we get some of it for our use by letting the mountain-fed streams and rivers turn the turbines of hydroelectric plants. In this example we have solar kinetic energy being converted to heat energy, then to gravitational potential energy as it is lifted, then to mechanical energy as it runs back down the mountainsides, and, finally, to electric energy as it is converted by the generator the turbine turns. In a much less important way, we also use converted solar energy with windmills and sailboats. Here the conversion route is light energy to heat energy to mechanical energy.

The other important way in which radiation interacts with matter is chemically. If radiation of the proper energy strikes a molecule, it can cause molecular rearrangements — chemical reactions — to take place. One of these, the production of ozone at the top of the atmosphere, protects life on earth's surface. The other, photosynthesis, fuels life.

Ozone is formed when solar radiation splits an oxygen molecule into two oxygen atoms. One of these atoms then combines with another molecule of oxygen to form O₃, ozone. This molecule strongly absorbs ultraviolet radiation. The O₃ layer at the top of the atmosphere thus acts as a protective layer against this energetic radiation which otherwise would arrive at earth's surface in lethal amounts.

Photosynthesis is a more familiar reaction. We can describe what takes place in the following way:

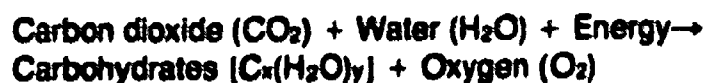

The carbohydrate molecule, whose general formula we give, is an important part of plant life. Ordinary sugar, for instance, is a carbohydrate whose formula is

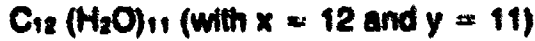

The process of photosynthesis is one, therefore, which converts radiant energy to chemical potential energy. The energy stored in the carbohydrate can be released by burning it (or in chemical terms, oxidizing it). This reaction is the reverse of the one above:



Photosynthesis is the source of the food energy we depend on. It is also the source of the chemical energy

that was stored in the swampy jungles of ancient earth and formed the fossil fuels—coal, oil, and natural gas. When we burn these fuels we are using stored solar energy.

We should not leave our brief discussion of solar energy without mentioning its source. The sun's energy is "thermonuclear" in origin. The sun's interior is hot enough that a "nuclear reaction" takes place. Bare hydrogen nuclei, protons, stripped of their atomic electrons by countless collisions, combine (fuse) to form helium. In the process some of the mass of the hydrogen is converted into energy; it is this energy converted to radiant form which travels the 93 million miles to earth.

Only a small fraction reaches earth, of course. The sun radiates in all directions and only 4 parts in 10 billion of the total power emitted reaches earth. But this is

FIGURE 1-1
Power Inputs to Earth

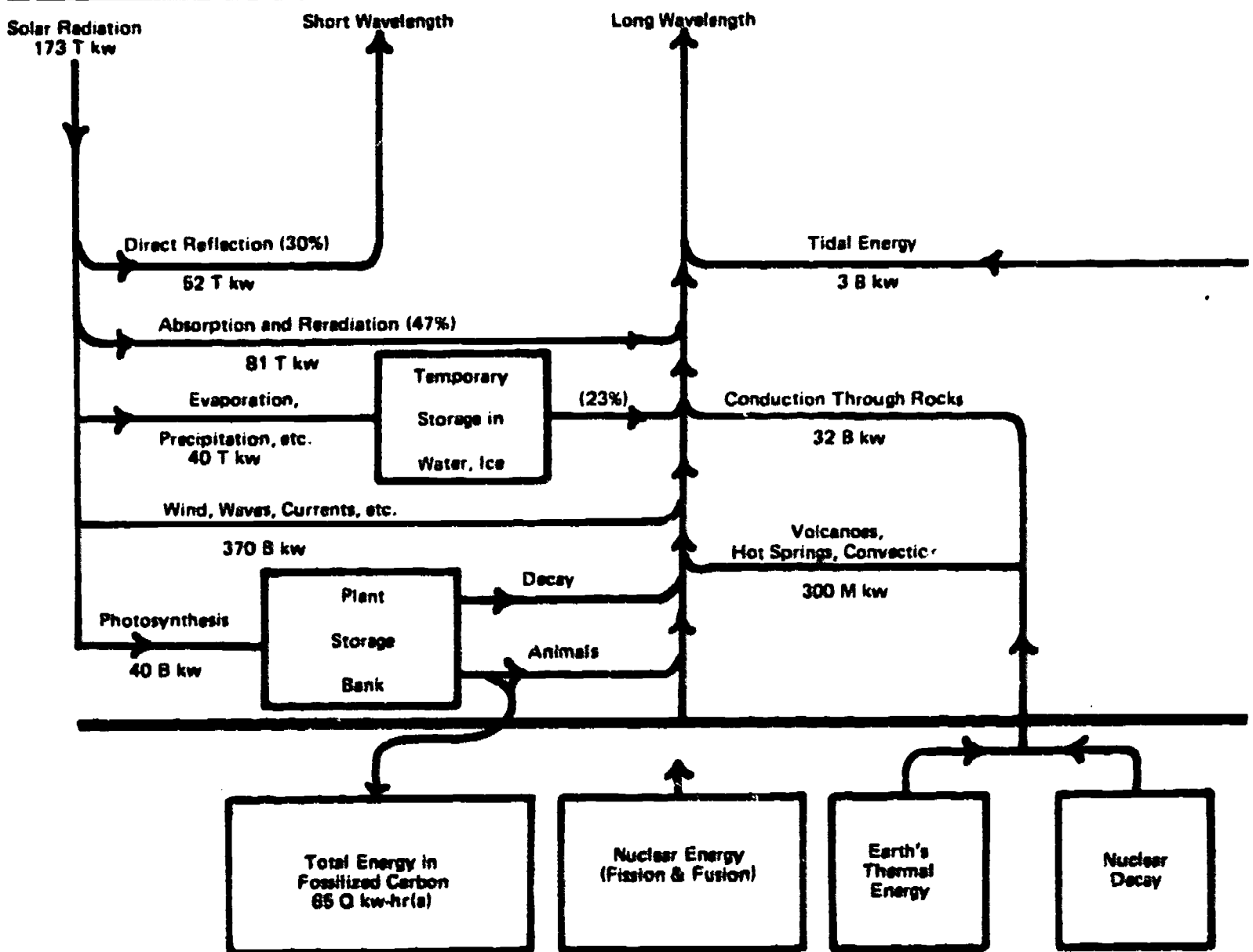

Q = Ten, 1,000,000,000,000,000
 T = Trillion, 1,000,000,000,000
 B = Billion, 1,000,000,000
 M = Million, 1,000,000

(a) This is an energy unit, power times time.

Data from M. King Hubbert, "The Energy Resources of the Earth," Scientific American 224, 62-63, September 1971.

plenty; the 173 T kw shown in Figure 1-1, if stored for 24 minutes, could provide for all the energy used by the human race in 1970.

Chemical energy: The most important form of stored energy is the chemical potential energy of the fossil fuels. The energy in coal, for instance, was originally solar energy 300 or so million years ago. The huge mosses and ferns of the Paleozoic coal swamps died and fell into the mud. They were acted on by anaerobic bacteria that released much of their hydrogen as a gas. This in turn was driven off by the heat and pressure generated by the tons of sediment that covered them. In the process the carbohydrates were converted to the almost pure carbon of coal.

When the carbon atom is burned (oxidized), it releases the remaining stored energy in the reaction:



Some plant and animal life sank to the bottom of the great sea beds and went through a different chemical transformation under pressure and heat to form the "hydrocarbons," the complicated molecules of hydrogen and carbon characteristic of petroleum. Their stored energy is also released by burning.

In Table 1-3 we show the amounts of energy contained in the traditional measures of the fossil fuels; tons of coal, barrels of oil, and thousands of cubic feet of natural gas. For comparison, we also show the energy per pound of all of these. This latter comparison shows that energy per pound (the energy density) is greatest for natural gas, which is one of the reasons for the popularity of this fuel.

Chemical energy is used by man in other forms. Food energy is of this form. The energy stored in a battery is also chemical, stored in molecular rearrangements there and released when electrons are allowed to move through an external circuit. An important

TABLE 1-3
Energy Content of Various Fuels

Fuel	Amount	Energy Equivalent (M Calories)	Energy per Pound (Calories)
Coal			
Soft coal (bituminous)	one ton	6.1	3,100
Hard coal (anthracite)	one ton	6.4	3,200
Oil, distillate (including diesel)	barrel	1.5	4,900
Gasoline	barrel	1.3	4,800
Natural Gas	1,000 ft ³	.26	5,000
Wood	1 cord ^(b)	5.3	1,250

(a) Million.

(b) One cord is a pile of wood 4 ft. long, 4 ft. high, and 8 ft. long.

device of the future, the fuel cell, will also convert chemical energy to electrical energy; it will be described in a later chapter.

Nuclear energy: A form of potential energy of growing importance is stored in the nucleus, the tiny, dense core of the atom. Nuclei are made up of the elementary particles, protons and neutrons. It is by rearranging these particles that nuclear energy is stored and released. The fission reaction and the fusion reaction are two important examples of this. In the fission reaction a heavy nucleus, such as uranium, is split into two lighter ones. In this process mass is converted into energy and it is this energy we obtain from the hot interior of a nuclear reactor. We describe this in more detail in Technical Appendix 6.

The fusion reaction involves very light nuclei. It is, as we have said, the source of the sun's energy. In a typical example, four hydrogen nuclei, by a complicated series of reactions, form a helium nucleus (two protons and two neutrons). Again, some of the mass has been converted to energy. It is a fusion reaction involving a rare form of hydrogen, deuterium, which scientists are now trying to master so that we can use the deuterium in the ocean as the fuel in a controlled fusion reaction. Our only duplication of the sun's process so far has been to perfect the so-called "hydrogen bomb," and that did little to help us in our quest for energy.

Geothermal energy: The earth's interior is molten rock, "magma" the geologists call it. There is, of course, a tremendous amount of geothermal energy in the earth. It is stored kinetic energy — heat energy — insulated by the solid, thin crust on which we live.

We are not sure how the energy got there; it may have been stored in the molten blob of original earth or it may have come from the impact of countless chunks of matter pulled to it by the earth's gravity in that formative period. We are fairly certain, however, that it is the radioactivity of some of the material in the earth which keeps it hot. There seems to be enough uranium, potassium, radium, and other naturally radioactive material in the earth's interior to produce the relatively small amount of heat needed to make up for that lost through the surface. In this sense, geothermal energy is nuclear energy.

Energy from the core leaks out in different ways. As we see in Figure 1-1, the largest amount, 32 B kw, is conducted through the crust in the same way that the heat from a hot pan of water is conducted through the sides of the pan. The insulation of the crust is not perfect. As we dig down into it, it gets hotter, 48°C for each mile we go in.

This temperature difference is not great enough to be of use as an energy source, although, in the future, we may pipe water down heating it to warm our houses. The leaks that are useful to us are in those regions where the magma is close to the surface. Volcanoes, geysers, and hot springs are evidence of this. The total power arriving at the surface by "convection" — that is, by the movement of hot rock, water, or steam — is estimated in Figure 1-1 as 300 M kw.

Of this total output, only a limited amount can be used. If available as hot water or steam, it can be used to heat buildings. Some 500 homes and offices in Klamath Falls, Oregon, are heated by hot water drawn from a hot spring running under the town. The only large-scale use of it in this country is in the Geysers Valley in California where dry steam — steam so hot there is no water in it — is piped to steam turbines and used to generate electricity. There are now generators there producing a total of 500,000 kw of electric power, about half of San Francisco's needs.

Geothermal energy, like nuclear energy, is an energy of the future. We will describe later on more of the details of its use, its potential, and its problems.

Tidal energy: The last of the big five, tidal energy, is probably the least in importance for man's use. It is relatively big, on a human scale, 3 B kw (see Figure 1-1), but is dispersed over all the oceans' shores.

The source of this energy is the kinetic energy stored in the rotation of the earth-moon system. Like geothermal energy, it is another example of the successful temporary storage of energy in the kinetic form. This energy is converted to the motion of the oceans through the gravitational attraction of the moon on their contents. The oceans' water is pulled toward the moon on the near side (and bulges in the other direction on the far side). The up and down (in and out) motion of the water can be used to turn a turbine. Tidal energy is finally dissipated by friction with the ocean shores, warming them imperceptibly.

Tidal generation of electricity is only practical where geologic peculiarities cause high tides. The first tidal dam and generator was built in the Rance estuary on France's Brittany coast, where tides rise and fall as much as 44 feet. It has a total generating capacity of about 300,000 kw.

There has also been some interest in building a tidal conversion facility at Passamaquoddy Bay on the far northern coast of Maine, but it does not yet appear commercially feasible. We cannot expect much contribution to our total supply of energy from the tides.

Summary

In this chapter we have tried to introduce you to the various forms of energy, the laws that govern its conversion from one form to another, and the patterns of energy flow that power the great natural engines of earth as well as man's puny manufactured ones.

Energy can be classified into two types, kinetic and potential energy. It is used in the kinetic form as heat, light (or, more generally, radiation), and motion. It is stored in the potential form.

Energy is used by conversion from potential to kinetic form or from one kinetic form to another. We have presented and discussed the two laws that govern all these conversions:

1. **Energy can be neither created nor destroyed.**
2. **In any conversion of energy from one form to another some of it becomes unavailable for further use.**

This second law, the "heat tax," will prove to be the most important to our understanding of the Energy Crisis.

In this chapter we define and give examples of the units in which we measure energy and power. We also define work, which is the word we commonly use for mechanical energy in man's use. The standard unit of work and energy in our presentation will be the *Calorie*, the energy required to raise the temperature of one kilogram of water one degree Celsius. The power unit will be the unit of electric power, the *kilowatt* (kw), whose definition we defer to Technical Appendix 3.

In the final section we look at the patterns of energy flow on earth. We see the dominance of the solar input and compare it with the nonsolar continuous sources of power, the tides and the molten interior of the earth. We end with the identification, from Figure 1-1, of the five primary forms of energy on earth: the three kinetic forms, *solar*, *geothermal*, and *tidal*, and the two potential forms, the chemical energy of the *fossil fuels* and the *nuclear energy* stored in the atom's core.

The rest of our story will revolve around these five forms and what happens when they are mined, tapped, or trapped and then burned or otherwise turned to our uses. The next question is, however, "How much is there?" We shall answer that in the next chapter.

Force, Work, Energy, and Power

What is energy? In the beginning of Volume II of this Source Book, we said: "energy is energy." A common definition is that "energy is the capacity to do work." Unfortunately, neither definition is satisfactory; work and energy are both left undefined.

In science, where verbal statements usually have mathematical expression, precision of definition is of primary importance. To gain precision, terms such as energy, force, and work are defined "operationally," that is, by the operation necessary to observe or measure them. In this Appendix we will make some such definitions, review the relationships between these quantities, and provide some of the mathematical expressions which allow us to represent them by numbers. We also provide a table of conversion factors between the various units in which energy and power are measured.

Force, Mass, and Acceleration

We will get at the definition of energy indirectly by linking it with force. Force is an easier concept to understand; you might say we have some "feel" for it.

If asked to define a force, we might say "a push or pull," but this is still not precise. We cannot put numbers in such a statement. The operational definition of a force connects it to the change in velocity, the acceleration, of an object. It was Isaac Newton, the great 17th-century physicist, who gave us this definition in his famous relation

$$f = ma \quad \text{Eq. A3-1}$$

This equation connects force f to acceleration a (where $a = \Delta v / \Delta t$, the change in velocity Δv divided by the time Δt over which that change took place), the constant in the equation, m , is the mass of the object.

We can measure a by measuring the change in velocity and the time. The operational definition of force therefore, will be complete if we provide a way to measure mass m . Fortunately, this is easy. There are standards of mass ("measure" means, after all, "compare with a standard"). In the scientific system the standard mass is the kilogram, a thousand grams. Thus, to measure mass one compares the unknown mass with the standard using a balance of some sort.

The units of mass and acceleration are kilograms and meters per second per second respectively. Force thus has the units

$$f = ma \text{ (kg - meters per sec}^2\text{)}$$

We define a unit of force, the newton, as $1 \text{ kg} \times 1 \text{ m/sec}^2$ or, equivalently, a force of one newton will cause a one-kilogram mass to increase its velocity one meter per second each second. This is a satisfactorily precise definition of force.

To use a familiar example, a mass near the surface of the earth feels a force on it which we call its *weight*. (The weight is, of course, the pull of the earth's gravity on the object.) This force is defined as

$$f = mg \quad \text{Eq. A3-2}$$

where m is mass as before and we use g for the acceleration of gravity, 9.8 meters per second². A 1 kg object, therefore, weighs 9.8 newtons. In the (soon to disappear) English system, weights are in pounds. The rule for conversion from one to another is

$$1 \text{ pound} = 4.45 \text{ newtons}$$

Force, Work, and Energy

We need now to connect the concept of force to the more abstract concept of energy. We do have some intuitive comprehension of energy; we avoid moving cars, stay out from under lifted pianos, and move away from the front of bent bows. In all these examples a familiar object has had something added to it which makes it different; the car because it is moving, the piano because it is lifted, the bow because it is bent. This added quantity is energy.

In Chapter 1, Volume II, we describe the two kinds of energy: *kinetic energy*, the energy of motion; and *potential*, or stored energy. In our examples the car has kinetic energy, the lifted piano and bent bow have potential energy. From the relationship between these two energy forms in the familiar example of a falling body, we can gain some insight into the relationship between force and energy.

Suppose we drop a ball of mass m from a distance h above the ground. Just before it strikes the ground it has an amount of kinetic energy

$$KE = 1/2 mv^2 \quad \text{Eq. A3-3}$$

(Equation A3-3 is the general expression for kinetic energy.)

Where did this kinetic energy come from? Clearly, it was stored in the ball by the action of lifting it the height h . Already we see the necessary involvement of a force; it took a force to lift the ball. We can make the relationship precise by inserting into Equation A3-3 the velocity v in terms of the acceleration of gravity g and the height h . This is

$$v = \sqrt{2gh}$$

or

$$v^2 = 2gh$$

Inserting this expression for v^2 into Equation A3-3 gives

$$KE = mgh$$

*This expression can be found by simple calculus from the relationship between the acceleration and the velocity.

On the left we have the kinetic energy, on the right a term that involves a force mg (the *weight*, see discussion of Equation A3-1) and the distance h . This term must be the potential energy (the kinetic energy must equal the potential energy, according to the First Law of Thermodynamics — see discussion in Chapter 1, Volume II). Thus the potential energy of an object of mass m lifted a height h is increased by the amount of mgh .

The potential energy is the product of a force times a distance. To store this potential energy we had to exert a force (we'll call it the lifting force) throughout that distance h , and that lifting force had to oppose the force of gravity.

In every case of stored energy we investigate, we find the same factors: a force must operate against an opposing force. The application of this force over a distance is what we call *work*. It is this work that produces the change in potential energy which occurs in lifting the object. It is also work that produces the change in kinetic energy when the object is dropped. In that case, the force is the gravitational force itself, acting over the distance h , pulling the mass back to earth. In the first instance we did work, in the second the earth's gravity did the work.

The computation of the work, the product of force times distance, is relatively easy when the force is constant and in the same direction as the motion. If, however, either of these conditions is altered the computation of the work becomes more complicated (and we leave it to physics texts).

Work as the Change in Energy

We are much concerned in this book with energy conversions. Since we know that energy is neither created nor destroyed, its use must be through conversion. Work is the name we give to a large class of those conversions, those which are to or from, mechanical forms. Thus we do work in lifting the object we have been describing and in so doing convert mechanical energy to gravitational potential energy. We obtain work from an electric motor, which converts electric kinetic energy to mechanical kinetic energy. Work is characterized, as we have seen, by the operation of a force over a distance. If the system supplies the force, as in the falling body case, then work is done *by* the system. If the force is supplied externally, by a man lifting the objects, then work is done *on* the system. The final result of the investment of work, on or by a system, is a change in the energy of at least that part of the system on or by which the work is done.

We can make a further very important point about energy storage before we leave it. Consider the lifting force we had to apply to store potential energy in the lifted mass. We treated it as if it were equal to the force of gravity. In fact, however, it must be a little greater than the weight mg if it is to cause the mass to move. Thus the energy expended (the work done, since it is the product of the lifting force times h) is a little *greater* than

the stored potential energy mgh . This extra work is the "heat tax" we introduced in Chapter 1, Volume II. It does not go into potential energy. It goes instead into heat, frictional heat with air and energy that is converted to heat in our arm muscles (or somewhere) when we stop the object at the height h . In every case of stored energy we might consider — in the charging of a battery, for instance — the force that causes the storage must be a little larger than the force it opposes, and the extra energy pays the heat tax.

Work Against Dissipative Forces

We have so far considered work done in storing energy. Much work is done also just to move things around. In this case there are also opposing forces that use up the work. We call these "dissipative forces." We will not try to either list or describe all the various important dissipative forces, only to make some general statements about them. Most of these dissipative forces oppose motion. The most common example is friction — caused by the adhesive forces between solid surfaces in contact. The result of moving an object against this force is to convert work to heat energy. Another example is air resistance, a complicated resistance to motion that depends on the velocity of the moving object. Again the kinetic energy is converted to heat energy. Other important dissipative forces are the one due to electrical resistance (which we will discuss in Appendix 5) and the more sophisticated force which opposes the motion of electric conductors in magnetic fields.

It is these dissipative forces which are, for the most part, responsible for the heat tax on energy conversions and for the eventual downhill run of all forms of energy to heat energy.

The Three Basic Forces

We have now provided the link between force and energy. In order to change the energy of an object we must apply a force over a distance and either move it — thus giving it kinetic energy — or change its state in some way to give it potential energy. In this latter application, the storage of energy, the force works against an opposing force.

This relationship between force and energy provides a great simplification of the forms of potential energy. There are only three basic forces in the universe, the gravitational force, the electrical force, and the nuclear force. Thus, since we must work against one or the other of these to store potential energy, there can be only three kinds of potential energy in the universe, gravitational potential energy, electrical potential energy, and nuclear potential energy.

We can rate these forces by their strengths. The gravitational force is by far the weakest. We must deal with very large masses — mountains or the earth or the sun — before we notice its effects.

The electrical force is next in size. It is about 10^{36} (a 1 and 36 zeros) times stronger than the gravitational force. It is the most important force on a man-sized

scale. It holds atoms and molecules together and is thus responsible for most of the secondary forces familiar to us: the forces of springs and rubber bands, surface tension, friction, adhesion, air resistance, and so on. It should be clear that the dissipative forces are almost all electrical in nature.

The strongest force is the nuclear force. We don't know as much about it as we do about the other two, but it has to be stronger than the electrical force because it holds a nucleus full of protons together. (Since protons are alike they electrically repel each other.)

The potential energies that derive from the gravitational and nuclear forces are fairly obvious. The energy of water lifted to a mountaintop by air currents is gravitational potential energy. The energy released in fission or fusion comes from nuclear potential energy. It is the electrical force that provides the greatest variety. The energy stored in coal, oil, natural gas, or wood is electrical potential energy. (We call it "chemical energy" in Chapter 1, Volume II, but that means the same thing.) The energy of a stretched string, a bent bow, or a charged battery is also electrical potential energy stored in the molecular changes in the substance. Nuclear energy powers the sun and stars, gravitational energy is stored in the great masses of the universe, but electric energy shapes and fuels the world of man.

Units

We have defined force, work, and energy. In Chapter 1, Volume II, we defined that other important quantity, power, as the work done per unit time, or symbolically

$$P = \frac{W}{t}$$

None of these definitions are complete, however, until we discuss units. These tell us the size of the "measuring stick" we are using, whether we have a foot ruler or a yardstick, to carry out the analogy. Since work is defined as a change in energy, both work and energy are expressed as force times distance. In the metric system, force is in newtons and distance in meters; the unit of work is newton-meters and is called a *joule*, after the Scottish physicist, James Joule, who did much to establish the Law of Conservation of Energy. A 50 kg woman (weighing 490 newtons, or 110 pounds) who lifts herself a vertical distance of 6 meters (about 20 feet) by walking up a flight of stairs will do 2,940 joules of work.

In the English system of units, force is in pounds, distance in feet, and the unit of work is foot-pounds. In these units the woman does about 2,200 foot-pounds* of work.

Since work can bring about changes in other forms of energy and can in turn be derived from conversion of other forms of energy, other units are often employed in the discussion of work and energy. The most important of these are the units by which heat energy is measured:

the Calorie and the British Thermal Unit (BTU), and the electric energy unit, the kilowatt-hour. This latter unit is obtained by multiplying a unit of power by a time. There is similar variety in the units of power. Since power is work or energy divided by time, obvious units are joules per second or foot-pounds per second.

The most familiar unit of power is the horsepower which is roughly the rate at which a horse can work for an extended time. The definition now has been made more precise: one horsepower is defined as 550 foot-pounds of work per second. Thus, in the example of the woman climbing the stairs, if she made it up the 20-foot flight in 10 seconds, she would have operated at just under one-half horsepower. If, however, she raced up them in 5 seconds, her output would have been almost one horsepower.*

The unit of power used in this Source Book is the watt, the name given (in honor of James Watt, who contributed so much to the understanding of the steam engine) to the power unit, one joule per second. It is applicable to any measurement of power. One horsepower, for instance, is equivalent to 746 watts of power. The watt, and its larger brother, the kilowatt (1,000 watts) are most often used, however, to measure electric power (which will be discussed in a later appendix).

In order that you can move easily among the many units in which the energy-environment crisis is described, we provide, in Table A3-1, definitions of all the commonly used units of energy (work) and power, and, in Tables A3-2 and A3-3, the appropriate rules for converting one to another.

*a) $2,166 \text{ ft-lbs}/10 \text{ sec} = 217 \text{ ft-lbs/sec}$
horsepower = $(217 \text{ ft-lbs/sec}) \times (1 \text{ H.P.}) / (550 \text{ ft-lbs/sec}) = 0.4 \text{ H.P.}$
b) $2,166 \text{ ft-lbs}/5 \text{ sec} = 433 \text{ ft-lbs/sec}$
horsepower = $433/550 = .79 \text{ H.P.}$

*2,940 joules divided by .305 m/ft divided by 4.45 newtons/lb = 2,166 ft-lbs.

TABLE A3-1
Commonly Used Units of Energy and Power

Energy Units	Definitions
*Calorie (or kilocalorie)	The amount of heat energy needed to raise the temperature of 1 kilogram of water 1 degree Centigrade (see Appendix 4).
BTU (British Thermal Unit)	The amount of heat energy needed to raise the temperature of 1 pound of water 1 degree Fahrenheit (see Appendix 4).
foot-pound	The energy required to lift a 1-pound weight 1 foot.
joule	The energy supplied by a force of 1 newton applied for 1 meter (see definition of newton in text of this appendix).
watt-hour	The energy supplied by 1 watt of power in 1 hour (see definition of watt under Power, this appendix).
*kilowatt-hour	10 ³ or 1,000 watt-hours.
horsepower-hour	The energy supplied by 1 horsepower of power in 1 hour (see definition of horsepower, this appendix).
Power Units	
horsepower	A time rate of energy expenditure of 550 foot-pounds per second.
watt	A time rate of energy expenditure of 1 joule per second (see also Appendix 5).
*kilowatt	10 ³ or 1,000 watts (see Appendix 5).

* Denotes those units we use most frequently.

TABLE A3-2
Conversions—Energy Units

In One	There Are	
Calorie	4	BTU
Calorie	3.1×10^3	foot-pounds
Calorie	4,200	joules
Calorie	1.16×10^{-3}	kilowatt-hours
Calorie	1.6×10^{-3}	horsepower-hours
BTU	0.25	Calories
BTU	780	foot-pounds
BTU	1,055	joules
BTU	2.9×10^{-3}	kilowatt-hours
BTU	2.9×10^{-3}	horsepower-hours
foot-pound	3.2×10^{-4}	Calories
foot-pound	1.3×10^{-3}	BTU
foot-pound	1.4	joules
foot-pound	3.8×10^{-7}	kilowatt-hours
foot-pound	6.1×10^{-7}	horsepower-hours
kilowatt-hour	860	Calories
kilowatt-hour	3.4×10^3	BTU
kilowatt-hour	3.6×10^6	joules
kilowatt-hour	2.7×10^6	foot-pounds
kilowatt-hour	1.35	horsepower-hours
horsepower-hour	640	Calories
horsepower-hour	2.5×10^3	BTU
horsepower-hour	2×10^6	foot-pounds
horsepower-hour	2.68×10^6	joules
horsepower-hour	.75	kilowatt-hours

TABLE A3-3
Conversions—Power Units

In One	There Are	
kilowatt	1,000	watts (joules per second)
kilowatt	740	foot-pounds per second
kilowatt	.24	Calories per second
kilowatt	.98	BTUs per second
kilowatt	1.3	horsepower
horsepower	550	foot-pounds per second
horsepower	.75	kilowatt
horsepower	.18	Calories per second
horsepower	.71	BTUs per second

Heat and Heat Engines

Although we rarely think about it, it is a near miracle that we can burn a fuel and use the heat energy to cause an engine to turn. It is that "miracle" we analyze in this Appendix. We begin with a consideration of the remarkable form of energy we call heat. As always we must first establish a vocabulary for its description and lead off with *temperature*, for it is clear that the concepts of hot and cold are somehow related to heat energy.

Temperature

We can distinguish between hot and cold objects by feel, and can easily rank a group of similar items from hottest to coldest. If we are to use the hot-cold concept scientifically, however, we have to measure — to put numbers with it. For that purpose we need to find some material that undergoes a distinctive change in property (in color, length, or electrical resistance, for instance) as it becomes hotter or colder, and use it to construct a "thermo-meter." Mercury, the liquid metal, fills the bill. Confined in a small-diameter transparent tube it responds to temperature change by expanding or contracting. These changes in height can be calibrated to give numerical values to the temperature. This is the common mercury thermometer.

The numerical calibration is, of course, the key. We must establish a temperature scale. Two reference temperatures and a decision on the size of the divisions are needed.

There are two common numerical scales now in use, the *Fahrenheit* scale and the *Centigrade** scale. For the Fahrenheit scale, the two reference temperatures originally chosen were: zero degrees Fahrenheit (0°F) as the temperature of a mixture of salt and ice (and water); 100°F as the temperature of the normal human body.

The choices of reference temperatures of the Fahrenheit scale were not good ones as neither temperature is precisely determined. The choices for the Centigrade scale were more successful: zero degrees Centigrade (0°C) was established as the freezing point of water; 100°C as water's boiling point (both at atmospheric pressure). The Fahrenheit scale was eventually standardized to the same points, so that now, in degrees Fahrenheit, water freezes at 32°F and boils at 212°F.

The relationship between these two scales is shown in Figure A4-1. From this figure we see how to convert from one scale to another. There are 180 Fahrenheit degrees between the freezing point and the boiling point of water, and 100 Centigrade degrees between the same reference points. Thus, the desired Centigrade temperature will be represented by 100/180, or 5/9, as many degrees as the Fahrenheit interval. If the Fahrenheit temperature is 122°F, then the interval is

122° minus 32°, or 90°F. The desired Centigrade temperature, T_C , is, therefore,

$$T_C = 5/9 (T_F - 32)$$

or

$$\begin{aligned} T_C &= 5/9 \times 90 \\ &= 50^\circ\text{C} \end{aligned} \quad \text{Eq. A4-1a}$$

To find a Fahrenheit temperature T_F given a Centigrade one, we work backward. If the Centigrade reading is 80°, the T_F is $9/5 \times 80$, or 144°F above the freezing point. The Fahrenheit temperature is, therefore, $144 + 32 = 176^\circ\text{F}$. Symbolically,

$$\begin{aligned} T_F &= 9/5 (T_C) + 32 \\ &= 9/5 (80) + 32 \\ &= 176^\circ\text{F} \end{aligned} \quad \text{Eq. A4-1b}$$

Heat Energy and Hot Gases

With the concept of temperature in hand, so to speak, we can now attack the concept of heat energy. It was the English physicist, Joule, who demonstrated the exact equivalence between mechanical energy and heat energy, and also the equivalence between electric energy and heat energy. Through many experiments he verified that there are fixed "exchange rates" between the different energy forms, in much the same manner that there are fixed exchange rates between the currencies of different countries. In other words, he demonstrated that heat and electricity are forms of energy in the same way dollars and francs are forms of money.

Heat, however, occupies a unique role in the energy picture. An amount of energy of one form can be *entirely* converted to an equivalent amount of heat energy, but a

FIGURE A4-1
Comparison of Centigrade and Fahrenheit Temperature Scales

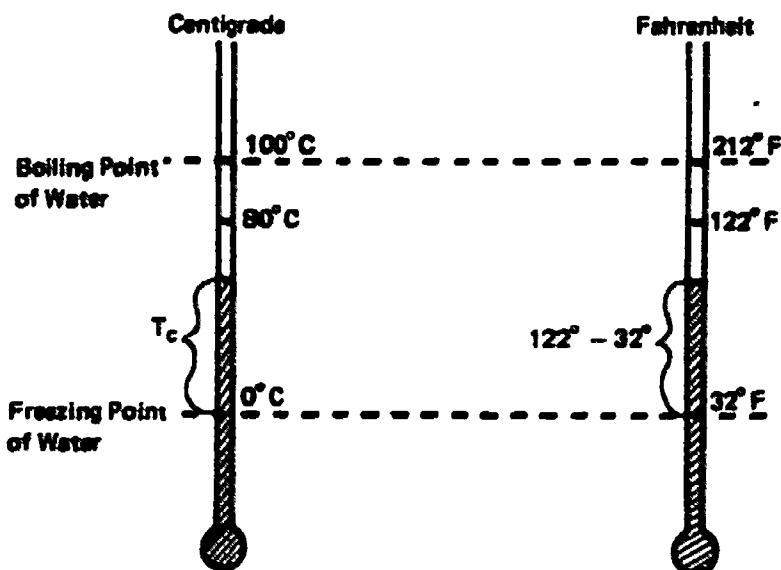

*Also called the Celsius scale.

given amount of heat energy *cannot* be entirely converted to another form of energy, such as mechanical energy. This is one way of stating the **Second Law of Thermodynamics**. It is this law of nature that prevents us from creating an electric power plant that is 100 percent efficient; one that converts *all* the energy of its fossil fuel into mechanical energy to drive a turbine, which can in turn drive a generator to produce electricity.

In order to appreciate this unique role of heat energy, we need to examine nature with a magnifying glass to see heat energy as it appears at the molecular level.

Although the study of heat energy and molecular motion is a fascinating and full subject, we will leave most of it to the physics class and concentrate our attention on hot gases. It is in such gases as steam or the combustion products of gasoline that the conversion of heat energy to mechanical energy takes place.

Those properties of gases which are important for our purposes can be described in terms of a fairly simple model. Although a gas is a collection of weakly interacting molecules, we will think of these molecules as little steel balls bouncing off of each other and off the container's walls. We can explain the role of the three important properties of gases — *volume, pressure, and temperature* — in terms of this model.

The unique feature of a gas is that it has no definite volume, it expands to fill any container. An appropriate container for our purposes is the cylinder-piston arrangement of Figure A4-2.

In the arrangement of Figure A4-2a we know that the piston, which has a certain weight W , will compress the gas to a certain volume V and, at that volume (and temperature), the gas will exert a force that balances W . This force is provided by the pressure of the gas. What is pressure? It is defined as a force per unit area, $P = F/A$. It is used when the force is not exerted at a single identifiable point (by a rope or a rod, for instance), but instead force is exerted at all points over a surface, a condition that occurs when we deal with gases or liquids. In the example of Figure A4-2a, therefore, if the cross-sectional area of the piston is A , then the total

force exerted by the gas is $P \times A$, and it must equal the weight W if the piston is balanced.

The difference between a pressure and a force is perhaps best shown by the difference between the pressures in bicycle tires and automobile tires. Two bicycle tires support a force (weight) of 200 pounds when inflated to a pressure of 60 pounds per inch². Four automobile tires support a force (weight) of 4,000 pounds when inflated to a pressure of 25 pounds per inch². We leave it to the reader to find out what area of these tires must be in contact with the ground in order to produce the necessary forces.

How does a gas exert pressure? Remembering our simple model of the gas — molecules constantly in motion, colliding with each other and the walls — we can answer: The molecules also collide with the piston — uncountable numbers of them per second. When an object bounces off another object it exerts a force on it — a fact of common observation. Each molecule that collides with the piston, as in Figure A4-2b, exerts a force on the piston. The effect of the steady barrage of molecules is, therefore, an average force on each unit area — a pressure. The total force is, as we have already said, the product of this pressure and the total surface area. The pressure exerted by a gas depends on the number of molecules, on the mass of each molecule (heavier molecules can exert more force), and on their velocity (the faster they are going, the more force they exert upon impact).

Pressure and volume are now defined with respect to the model, where does temperature fit in? The temperature of a gas is proportional to the average kinetic energy of the gas molecules. Since the kinetic energy is given by $KE = 1/2 mv^2$ (see Equation A3-3, Appendix 3) — that is, it depends on v , the velocity — the molecules move faster as the gas warms up.

FIGURE A4-2
Molecular Model of Pressure on Piston

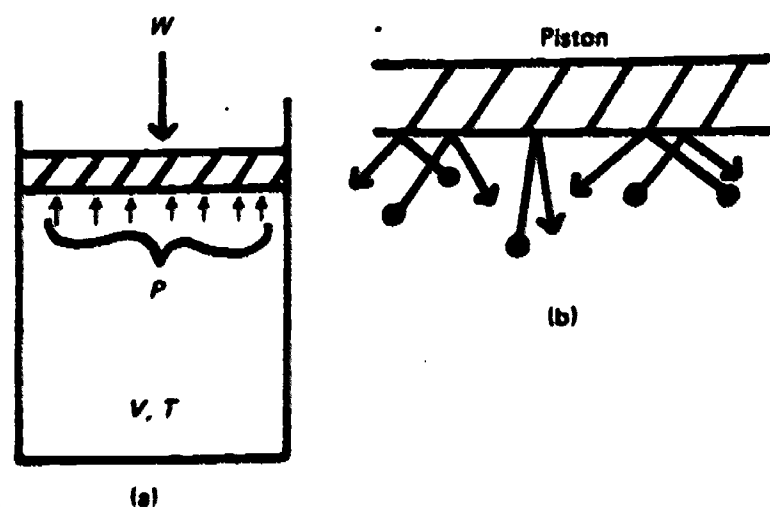
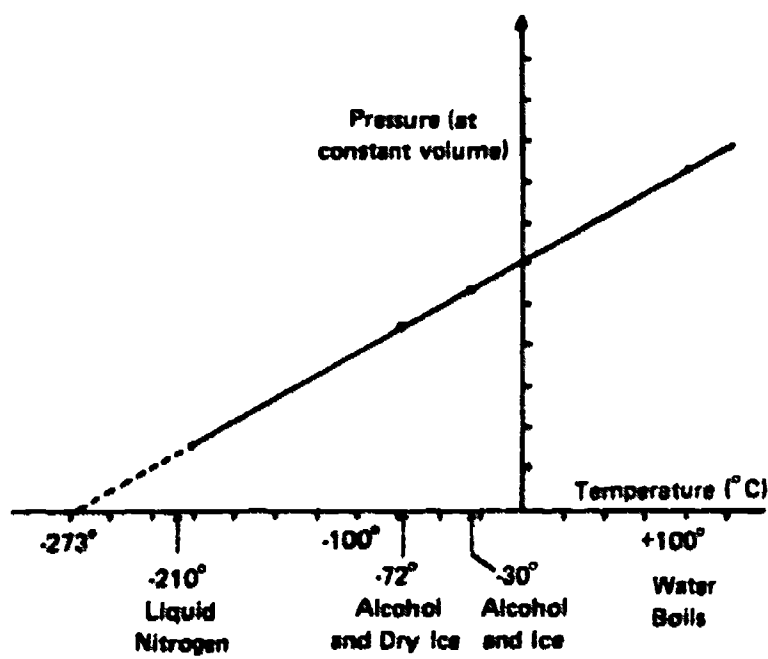

FIGURE A4-3
Relationship Between Gas Pressure and Temperature (constant volume)



This relationship between temperature and kinetic energy hides a condition of the temperature we must now make explicit. It should be clear, upon reflection, that temperature can no longer be defined arbitrarily as it was in the previous section. Kinetic energy is a specific quantity that is always positive — we can't have negative temperature.

The temperature scale we will use in the rest of this discussion will be the "absolute temperature scale." This is a scale for which zero is "absolute zero." What we mean by absolute zero can be made clear with the help of Figure A4-3.

Suppose we take a simple gas like nitrogen, confine it in a container (fixed volume), and then change its temperature and record its pressure. The solid straight line of Figure A4-3 would result. At some point most gases become a liquid (nitrogen at -210°C) and the straight-line relation ceases. If, however, we extrapolate that line to zero pressure, it intersects at -273°C . The remarkable fact is that all gases, even though their straight lines have different slopes, intersect at this same temperature. This point, where the pressure of an ideal gas becomes zero, is absolute zero. Since the pressure of the gas depends on the motion of the molecules, this implies that molecular motion ceases also at that temperature and, therefore, that the kinetic energy becomes zero. Absolute zero, of course, is a *limiting* temperature, it can't be reached. Helium, however, liquifies within a degree or so of -273.2°C . It is only for a temperature scale with zero at -273.2°C (or equivalently at -459.7°F) that the proportional relationship between T and $K.E.$ holds.

With this new temperature scale in use, the behavior of the pressure, volume, and temperature of a simple gas is summed up in the equation

$$\frac{PV}{T} = \text{constant} \quad \text{Eq. A4-2}$$

This tells us all we need to know for our purposes. We will look at one or two instances just to make the operation of Equation A4-2 clear.

Suppose we hold the temperature constant and reduce the volume. This could be accomplished with the apparatus of Figure A4-2 by pushing the piston farther into the cylinder. What happens to the pressure? By Equation A4-2, if T is constant and V decreases, then P must increase if the total is to remain constant.

Alternately, we might hold V constant and increase the pressure (by pumping more gas into the cylinder, for instance). In this case the temperature must increase along with the pressure in order to keep the entire term constant. We see this relationship demonstrated whenever we pump up a tire.

The most important consequence of Equation A4-2 as far as heat engines are concerned results from holding P constant and increasing T — by building a fire under the cylinder, for instance. In this case V must increase — the piston must move and work is performed.

Work from Heat

The fundamentals of an engine are shown in Figure A4-4. A gas at a pressure P , temperature T , and occupying a volume V , is put into thermal contact with a "hot reservoir," which is any large source of heat energy (like a steam boiler, for instance) that can continue to supply energy without changing its own temperature.

If the temperature of the cylinder (T_R) is greater than the temperature of the gas in the cylinder (T), then heat energy will flow into the gas, increasing its kinetic energy and, thus, the temperature of the gas. Since the piston is free to move, its weight keeps the pressure constant and, as we saw earlier, the result is that the piston moves upward increasing the volume. That work is done becomes obvious when we see that a force — the pressure times the area A of the cylinder — operates over the distance d .

This work comes from the heat energy provided by the hot reservoir. It is transmitted by the molecules bouncing off the piston. Since the piston is moving away from them when they hit it, they bounce off with a lower velocity than they came in with and thus carry away less energy than they came in with.

In this example all the heat energy was converted to work. This seems to violate the Second Law of Thermodynamics as we stated it earlier. The Second Law, however, applies to a complete cycle, not a simple, one-step operation as we have just considered. It is necessary, if we are to have an engine, to bring the gas

FIGURE A4-4
Work Performed by an Expanding Gas

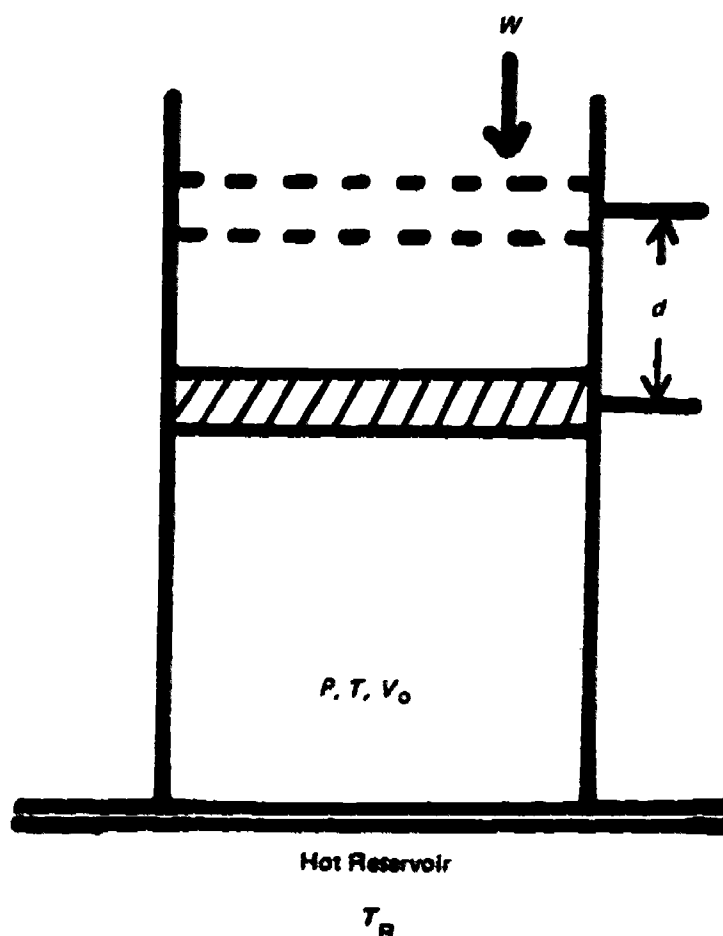

(the "working fluid") back to its original condition so the cycle can be repeated. In the simple cycle, we could push the piston back down, doing work and heating up the gas. The extra heat energy would then go back into the reservoir and we would have obtained no net work. A more complex cycle is needed.

The Perfect Cycle

Figure A4-5 shows an idealized four-cycle engine. It is for this engine that the efficiency equation of Chapter 3, Volume II, is derived. The operation of this "perfect" engine is as follows.

Step A — The gas (it can be steam or air or a mixture of combustion products) expands as heat energy is transferred from the hot reservoir to the gas.

Step B — The cylinder is removed from the heat source and placed on an insulated stand. The weight on the piston is reduced slightly and the gas continues to expand, doing work at the expense of its internal energy. Its temperature drops to the "exhaust temperature" T and, due to the collisions with the piston, the kinetic energy of the molecules decreases. The molecular collisions keep the piston moving.

Step C — The cylinder is now put into contact with a cold reservoir at temperature T_{out} . Gas heat energy now flows from the gas to the lower temperature cold reservoir. The molecules transfer some of their kinetic energy to the cold reservoir and, as a result, the gas volume decreases. The piston is performing work on the gas. This is an energy-wasting step, but clearly necessary if the piston is to get back to its initial condition so that it can repeat the cycle.

Step D — The cylinder is moved again to the insulated stand. The weight on the piston is now increased, allowing the compression to continue. During this step work is done on the gas, but, since no heat flow is allowed, this work increases the internal energy and, therefore, the

temperature of the gas. At that point, the cycle's end, the pressure has returned to its original value and the temperature is at T_{in} ; the process can be repeated.

The efficiency of this engine cycle is given by

$$\text{efficiency} = \frac{\text{energy out}}{\text{energy in}} \times 100 \text{ percent}$$

The useful energy out is, of course, the work; the only energy input is the heat which flowed in from the hot reservoir. Therefore,

$$\text{efficiency} = \frac{W_{out}}{Q_{in}} \times 100 \text{ percent}$$

Heat energy Q_{in} was put in during Step A and some heat energy Q_{out} was rejected during Step C. Since this is an ideal machine (no friction or heat leakage), the work done must be the difference between these two (since energy must be conserved). Therefore,

$$W_{out} = Q_{in} - Q_{out} \text{ and the efficiency is,}$$

$$\text{efficiency} = \frac{Q_{in} - Q_{out}}{Q_{in}} \times 100 \text{ percent}$$

or

$$= 1 - \frac{Q_{out}}{Q_{in}} \times 100 \text{ percent}$$

The next step is a big one. We won't derive it but only argue for its plausibility. The question is, what can the heat input and output, Q_{in} and Q_{out} , depend on? There is only one property available, the temperature of the reservoirs. Since we have seen earlier that the amount of

FIGURE A4-5
Heat Engine

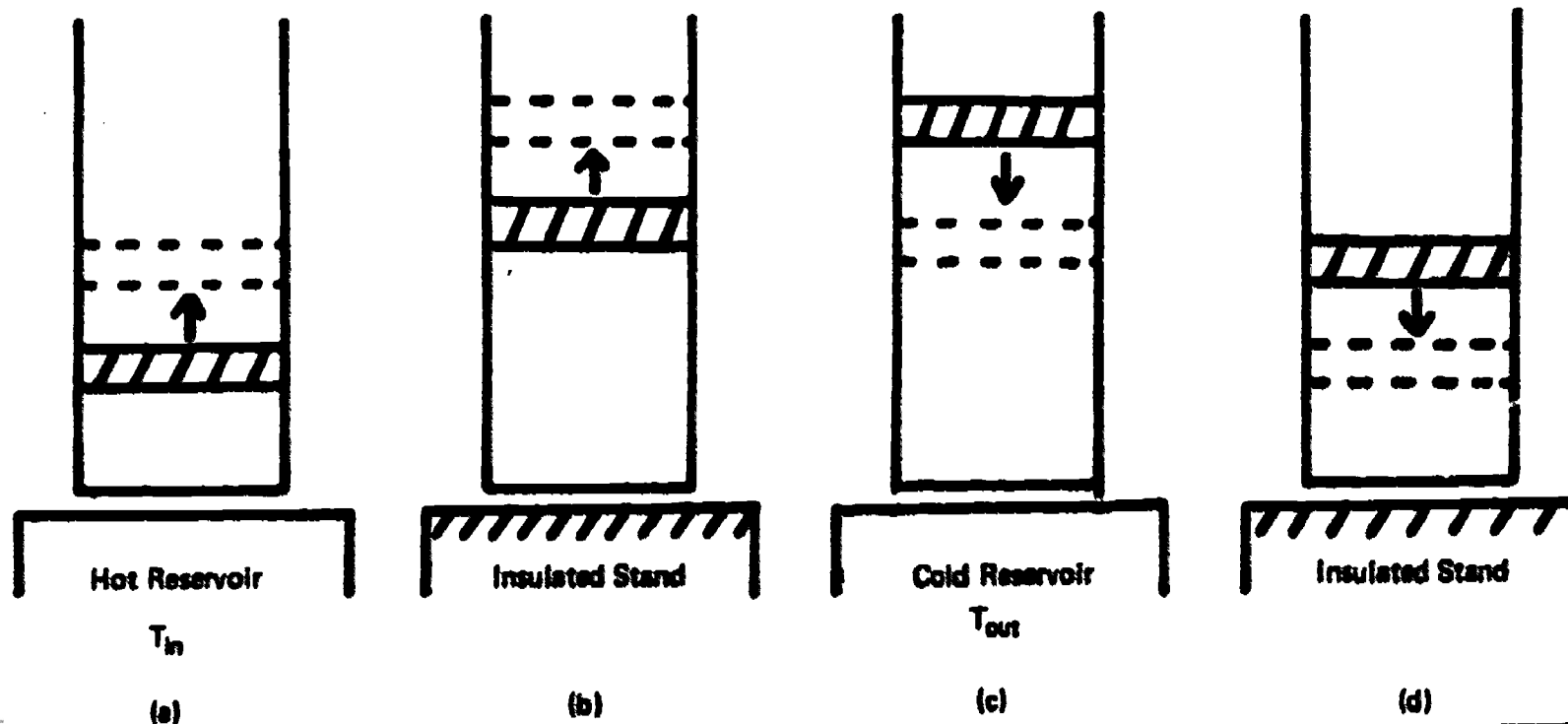

heat transferred depends on the temperature difference, we set the Q s proportional to the T s; that is, $Q_{in} / Q_{out} = T_{in} / T_{out}$, and write:

$$\text{efficiency} = 1 - \frac{T_{out}}{T_{in}} \times 100 \text{ percent} \quad \text{Eq. A4-3}$$

where T_{out} is the exhaust temperature and T_{in} the input temperature.

The fact that this cycle is reversible, that it can run backward using the work to lift heat from the cold to the hot reservoir, is due to its ideal nature; there are no losses due to friction, leakage, etc. It is this reversibility that makes it the "perfect engine." Carnot stated and proved that, in fact, no heat engine operating between the same two temperatures, T_{in} and T_{out} , can be more efficient than this "perfect engine." All real engines operating through the same temperature drop will have lower efficiencies. Such real engines are discussed in Chapter 3 of Volume II.

We see from this discussion that 100 percent efficiency is not possible. Even for the perfect engine which we have hypothesized, it is not possible to obtain $T_{in} = 0$ (for this is absolute zero) or $T_{out} = \text{Infinity}$. It is because some heat energy must be rejected in Step C that heat engines are intrinsically inefficient. We are stuck with this inefficiency as long as we have to rely on heat engines to convert fuel to work.

Generation, Transmission, and Distribution of Electricity

In Chapter 1, Volume II, we identified three intermediate forms of energy, thermal, mechanical, and electric. The first two of these are also important end uses of energy — most of the energy we use is in one or the other of these forms. Electric energy, however, is uniquely intermediate; it is energy in transit and must be converted to another form to be used. Electric energy is *kinetic energy* that is obtained when electric charges are set into motion by electric forces, just as mechanical kinetic energy is obtained when mass is set in motion.

We begin this Appendix with a vocabulary for electricity. We define the terms charge, current, voltage, and resistance with which electric energy and power are discussed. From these definitions we go on to discuss generation, transmission, and distribution of electricity.

Vocabulary of Electricity

Electric Charge

Electric charge resists verbal definition as tenaciously as does mass or any other of the fundamental quantities of science. It must be defined operationally as that quantity which gives rise to measurable electric forces and electric currents just as mass gives rise to gravitational force and momentum.

Electric charge differs qualitatively from mass in two important ways: 1. there are two kinds of electric charge — thus the electric force can be either repulsive or attractive; 2. electric charge is "quantized" — it comes in chunks.

Although the two kinds of charge are called positive and negative, they could have been called black and white, or male and female, or any other set of names which would have underlined their oppositeness. Positive and negative are convenient choices, since in combination the two can cancel, as happens in most bulk matter.

The most important carrier of negative charge is the electron, the elementary particle that is present in the outer "shell" of the atom and determines its chemical properties. The most important positive charge carrier is the proton, the nuclear "building block" that is 1,840 times as heavy as the electron. Protons along with uncharged, but massively similar, neutrons make up the nucleus — the core of the atom.

The proton and the electron have equal amounts of charge, even though there is the fundamental difference in quality — positive and negative. A series of experiments has shown that this amount is, in fact, the smallest amount of charge that exists in nature, and that all other charges are multiples, 1,2,3,4...etc., of the charge of an electron.

Charge can be measured in many different units. It could be measured in electron charges — a charge of 1,2, or 10^{24} electrons, for instance, but the smallness of this charge unit makes this impractical. We normally have to deal with too many electrons. The unit we will

use is the *coulomb*, named after Charles Coulomb, whose experiments led to the measurement of electric charge. The coulomb is a large unit of charge: the spark that zips from your finger to the doorknob after you have shuffled across a deep-pile rug carries only about 10^{-6} coulombs of charge; a bolt of lightning has only about 20 coulombs of charge. The charge on one electron is 1.6×10^{-19} coulombs or, conversely, it takes 6.25×10^{18} electrons to make one coulomb of charge.

Electric Current

The reason for choosing such a large unit becomes clearer when we talk of electric current — the transport of electric charge. It is easiest to define current in the case of electrons moving through a wire, as in Figure A5-1. The current, normally designated i , is the amount of charge passing through the cross-section A in one second. The common unit of current, the ampere (often shortened to amp), is one coulomb per second. Therefore, one ampere of current can consist of 6.25×10^{18} electrons passing through A in one second.

Voltage

Most people know that electric circuits in house wiring are labeled "110 volts." The volt is a unit of "potential difference," a term closely related to potential energy. We will define it by analogy to the gravitational case.

The potential energy of a mass m , lifted a distance h above the earth's surface is increased by mgh . This increase depends, obviously, on the mass m as will the work that produces that change. We can, however, define a quantity, potential difference, which is independent of m by dividing mgh by m . This gravitational potential difference gh describes the work per unit mass required to raise a mass a distance h .

In a similar manner, we can speak of a potential difference which is associated with electric charges and forces. In order to move apart two charges of opposite polarity (+ and -), which attract each other, or move together two charges of similar polarity (+ +, or - -), which repel each other, work must be performed on them. In doing this work we increase their potential energy. As in the gravitational case, we can define a potential difference as the increase (or decrease) in electric potential energy *per unit charge* or, equivalently, as the work per unit charge required to move charges. Electrical potential difference will, therefore, have the units of joules per coulomb. This combination of units has been given the name volt (after the Italian

FIGURE A5-1
Electron Flow in a Wire



physicist Alessandro Volta, who invented the first battery) and is defined as

1 volt = 1 joule of work per 1 coulomb of charge

To say that a potential difference exists between two points in an electric circuit, is to say that charge at one point will have a greater potential energy than at the other. If left free to move, charge will "roll down the potential hill": + charge travels from + to - potential and - charge in the reverse direction.

If you have a "12-volt" battery, this means that a positive charge at the positive terminal is at a higher potential energy than it would be at the negative terminal. That charge will "fall" in going from the + to the - terminal, performing 12 joules of work for each coulomb of charge that travels around the connecting circuit. This work comes at the expense of the chemical energy of the battery materials.

Electric Current in Wires

Given these definitions, we can discuss the nature of electric current within materials. The most important medium in which charged particles move, from our point of view, is metal — the copper and aluminum wires that carry electric current. In metals, atoms are bound together in a regular and repeating structure called a "lattice" in such a way that their outermost electrons are essentially "free"; the electrons are bound to the material but not to any particular atom. If an electric force is applied to the material, these free electrons can move from atom to atom within the lattice.

It is the "free electrons" which constitute the current in a wire. We visualize these electrons moving in the following way. A copper wire is used to connect the terminals of a battery. For the electron, the + terminal is a low potential, it is "downhill". Electrons at that end of the wire move on to the + terminal leaving that region of the wire positively charged. Free electrons from the region next to this one move in to fill the vacancy and leave their own vacancy behind them. In this manner the electrons in the metal are all set in motion toward the + terminal.

It is obvious that the circuit must be completed somehow. If the electrons just piled up on the + terminal, they would soon be numerous enough to repel any other electrons which tried to leave the wire and the current would cease to flow. It is the job of the battery to "lift" these electrons from the + terminal up to the - terminal where they can enter the wire at the other end.

When a piece of wire is connected between battery terminals, there is a potential difference set up immediately throughout its length. Said another way, each free electron in the wire feels a force that causes it to begin to move. This force field is set up very rapidly; essentially with the speed of light. When you switch on a light, electrons all along the circuit begin to move, current begins to flow, and the light comes on immediately, even though it will take a long time for an electron from the switch region to finally reach the light itself, if it ever does.

D.C. and A.C. Voltages

As we have already shown, the minimal components of an electric circuit are wires to provide and carry the electrons of the current, and a source of potential difference, which causes the electrons to move. We have so far considered only a constant potential difference such as is provided by a battery. A voltage (as we shall begin to designate potential difference) of the type put out by a battery is called D.C. (for direct current) voltage. Such a voltage plotted against time maintains a constant value and direction (that is, the positive terminal remains the positive terminal and the voltage remains 12 volts or 6 volts or whatever).

D.C. voltages have certain important applications: in automobile electric systems, in flashlights, and in electroplating, for example. From the point of view of total electric use, however, the more important type is A.C. (for alternating current) voltage. As is suggested by the name, an A.C. voltage changes in both magnitude and direction — the polarity of the output, + or -, regularly changes as does its numerical value. We will later describe how generators (or alternators, as they are called) produce such a voltage.

An A.C. voltage has the form, as a function of time, of

$$V = V_{\max} \sin \omega t$$

which is shown in Figure A5-2.

The parameter ω determines how many times a second an A.C. voltage changes from + to -. In the United States system, A.C. voltages "cycle" 60 times a second, that is, ω is 60 cycles per second (nowadays called 60 hertz) and the polarity is reversed 120 times per second. As we can see from Figure A5-2, it is no longer possible to talk of "the voltage" (or "the current") in the A.C. case, as both these quantities vary with time. What is usually specified is the "rms" value, which is about .7 times the

"rms" means root mean square, the square root of the average of the voltage squared. For a sinusoidal voltage as shown above, the rms value is $\sqrt{2}/2$ times the maximum.

FIGURE A5-2
A.C. Voltage

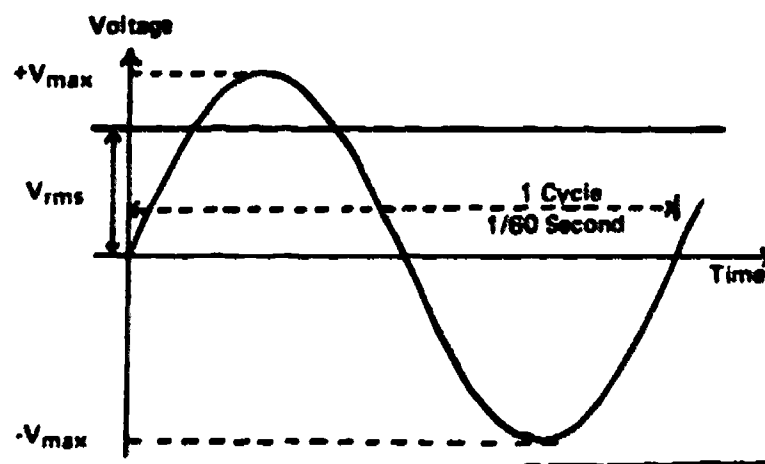

maximum value. Thus for 110-volt house current, since 110 volts is the rms value, the maximum value is 156 volts.

Resistance

We have identified electric current in wires with the movement of free electrons. When you try to move a charged particle — electron, proton, or ion — through any medium — gas, liquid, or solid — the motion will be resisted. There are, after all, other atoms about and their electrons will be attracted or repelled by the moving charge. They will take up some of its energy just as a moving billiard ball loses energy by collision with other billiard balls. This lost energy contributes to the motion of the atoms of the transmitting medium and, therefore, heats it up.

The motion of the free electrons through the metal is, thus, very erratic. In the first place, the electrons vibrate randomly at relatively high speeds due to the temperature. The applied voltage gives them a small component of motion in the direction along the wire. Thus, the electrons are bouncing wildly about but are drifting on the average in the direction of the electric field. In the metals used for wire, this drift speed depends only on the voltage applied. For this important class of conductors, the current i is proportional to the applied voltage V :

$$i \propto V$$

We can write this as an equation,

$$i = \frac{V}{R} \quad \text{Eq. A5-1}$$

where R is a constant that takes into account the resistance to motion just described. It depends on the cross-sectional area of the wire and on its length. R is called the "resistance" of the conductor. As the resistance increases, the current decreases and vice versa.

The common unit of resistance is the *ohm* (named for yet another pioneer in electricity, a German high school teacher, Georg Simon Ohm, whose experiments led to Equation A5-1). If V in Equation A5-1 is one volt and i is one ampere, then R is one ohm.

It is this resistance that accounts for much of the loss of electric energy in moving it from place to place. Those electric devices whose purpose is to convert electric energy to heat energy — space and water heaters, toasters, irons, for instance — depend upon high-resistance wires for the conversion. This conversion of electric energy to heat energy can be 100 percent efficient.

The discussion we have just given for resistance holds true whether the applied voltage is A.C. or D.C. The electrons are light enough to respond easily to the change in propelling force produced by an alternating voltage. Thus, the current in a resistive circuit has the same form and the same time relation (it peaks when the voltage peaks) as the A.C. voltage of Figure A5-2.

Electric Power

The final addition to the basic vocabulary of electricity is electric power. Power is work per unit time. Since potential difference — voltage — is work per unit charge — and current is charge flow — charge per unit time — power is dimensionally the product of volts times current.

$$\text{Power} = \text{voltage} \times \text{current} = \frac{\text{work}}{\text{charge}} \times \frac{\text{charge}}{\text{time}} = \frac{\text{work}}{\text{time}}$$

Symbolically:

$$P = iV \quad \text{Eq. A5-2}$$

Equation A5-2 is exact for D.C. voltages and currents. If A.C. voltages and currents are being considered it can be more complicated, since the voltage and current may not peak together (may be "out of phase," in the jargon). If the electric circuit is purely resistive, however, Equation A5-2 holds for A.C. also.

The unit of electric power is

$$P = \text{volts} \times \text{amps} \\ = \frac{\text{joules}}{\text{coulombs}} \times \frac{\text{coulombs}}{\text{second}} = \frac{\text{joules}}{\text{second}}$$

One joule per second is the "watt" we discussed earlier. One watt of power is, therefore, present when one amp of current flows across a potential difference of one volt.

We can also combine Equation A5-2 with Equation A5-1 and learn an important fact about electric power transmission. If we want to deliver a certain amount of power through a transmission line, then, since $P = iV$, we have a choice. We can deliver the power at high current and low voltage or the same amount of power at high voltage and low current: the product determines the power. To force a current i against the resistance R of the transmission line requires a potential difference $V_R = iR$. Thus, an amount of electric power, iV_R , is used up just in transmitting the current i through the line; it is "lost" as heat. This lost power P_e , depends only on the current, that is:

$$P_e = i \times V_R = i \times iR$$

or

$$P_e = i^2R \quad \text{Eq. A5-3}$$

It increases, in fact, as the square of the current. It is less wasteful, therefore, to ship electric power at high voltage and low current. We will examine this further in our discussion of the transmission of electricity.

The Commercial Generation of Electric Power

The three major steps in the journey of electric power are generation, transmission, and distribution. Each

step has its own characteristic problems and makes its own contribution to the national energy-environment problem. The complexity of the power industry is well symbolized by Figure A5-3, which shows all the major steps from fuel delivery to end uses of electricity in a city. The generation of electricity begins with a natural energy source such as gas, oil, or coal. The fuel might then go through special processing before it is sent into the furnace where it is burned to produce steam, which in turn powers the inevitable (and not very efficient) heat engine — the steam turbine. The conversion sequence is chemical energy to thermal energy to mechanical energy. At the end of the production line, the electric generator makes the final conversion to electric energy.

Generators

A simple system which illustrates the principle of electric power generation is shown in Figure A5-4. A "U"-shaped piece of copper wire with a cross piece that can slide on it is placed in a magnetic field. The magnetic field (indicated by the +s on the figure) is perpendicular to the plane of the paper. It could be formed by a north pole of a magnet above the paper and a south pole below the paper.

As we have mentioned before, in a piece of metal, such as copper, the atoms align themselves so that there are loosely-bound electrons, which we called free electrons. If the sliding cross piece is moved from position a to b, these electrons will be physically moved in the magnetic field.

Charges which move in a magnetic field are acted upon by a magnetic force. This is a strange force in

comparison to the electric and gravitational forces*. It depends on the velocity of the charge — if the charge is not moving, there is no magnetic force. Its direction of push or pull is strange also. It does not act along either the direction of magnetic field or the direction of motion of the charge, but is perpendicular to both of these. Thus, in Figure A5-4, where the magnetic field is pointed like an arrow into the plane of the paper and the motion of the wire moves the charge to the left in the plane of the paper, the magnetic force points from the bottom of the figure to the top. In other words, as the wire is moved to the left, free electrons are forced to move upward in the wire by the magnetic force.

If it were not for the rest of the circuit, the electrons would pile up at the end of the wire. The remaining circuit allows them to flow as a current I , shown by the arrows in the figure. The situation is almost the same as if the top of the slider wire was the positive terminal of a battery and the bottom the negative terminal; the U-shaped loop would be the circuit inside the battery. In other words, there exists a potential difference, a voltage, between the top and bottom of the slider.

This is the basic generator principle. A conducting wire is moved in a magnetic field, a force operates on the free electrons causing them to move and, if the system is properly constructed, a current can be caused to flow across a potential difference and electric power

*The magnetic force, however, is not a fourth basic force but, as can be shown using Einstein's relativity relations, is derived from the electric force.

FIGURE A5-3
Generation, Transmission, and Distribution of Electricity

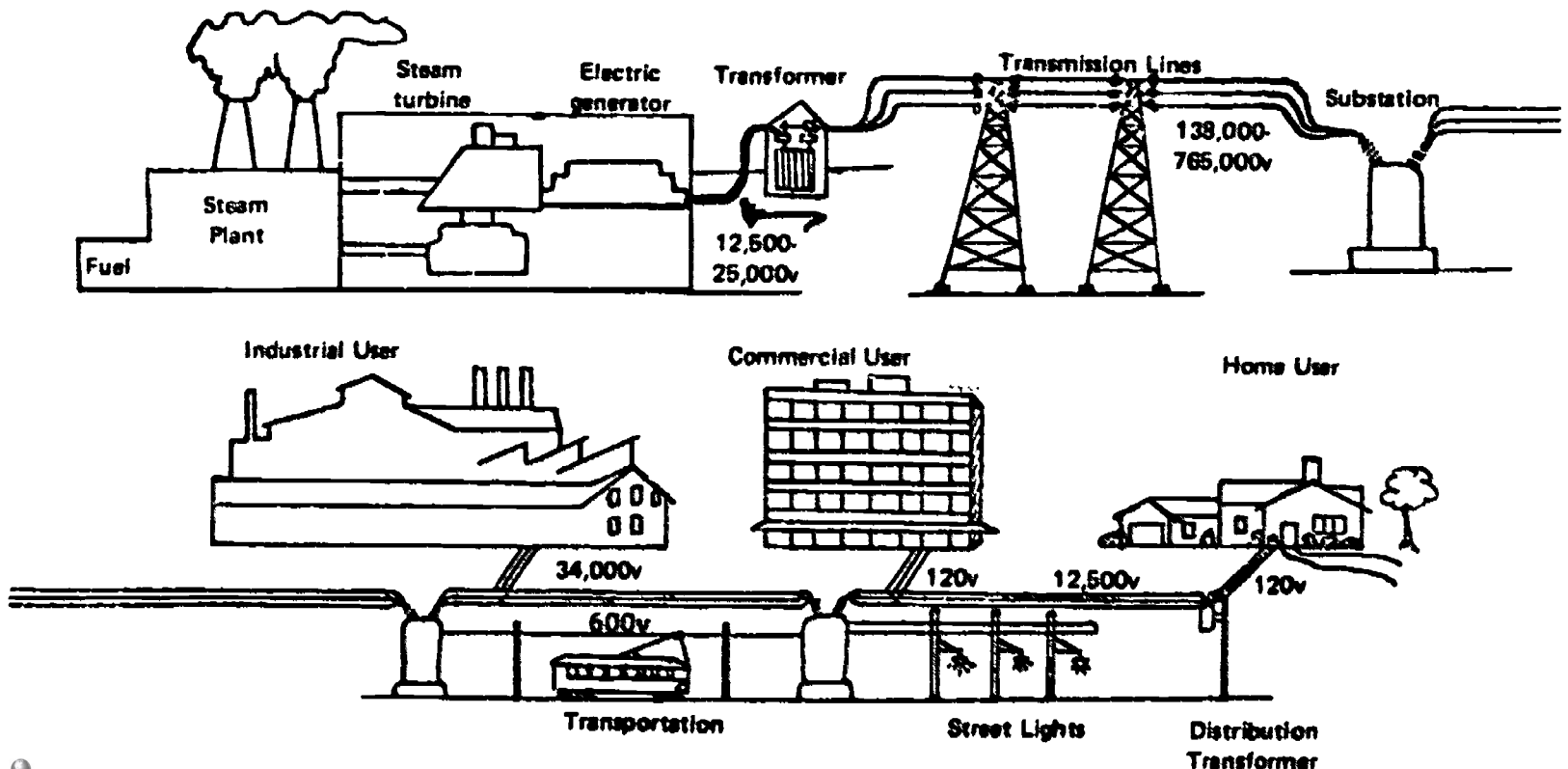

becomes available. We will come back to the question of "properly constructed" later. Let us examine this magic electric power more closely.

We seem to have gotten something for nothing. By sliding a conductor through a magnetic field we created energy. We know, however, that we did not create energy but converted it from one form to another. We had to do work to create the potential difference in the wire. How did this work come about? Let us look again at Figure A5-4.

Moving the conductor to the left in the magnetic field causes the current i to flow as shown. But a current is made up of moving charges. These charges are now moving up (in the drawing) and they also feel a magnetic force — this one is perpendicular to the direction of current flow and to the magnetic field. If we work out the direction of this force, it opposes v . We must, therefore, push against it to keep the conductor moving and, thus, do the work that is converted to electric energy.

The simple system of Figure A5-4 is not of much use as a practical generator. We would get tired pushing the slide wire back and forth. It is much more practical to turn a loop in a magnetic field, as we show in Figure A5-5. Rotary motion is easy to come by, turbines or engines produce it.

To see how we can generate a potential difference by turning a loop we must use a general law discovered 100 years ago by the English physicist, Michael Faraday.

In the example of Figure A5-4, we described the generation of a potential difference in terms of forces. It can be described equivalently in terms of a "magnetic flux." We can think of this magnetic flux, which we will symbolize by the Greek ϕ , Φ , as being the amount of magnetic field in the area A surrounded by the "U" and the slide wire. Figuratively, it could be thought of as the number of $+$ s (arrows seen from the rear) in the enclosed area. Faraday showed that a potential difference is generated whenever the magnetic flux Φ changes.

FIGURE A5-4
Generation of an Electric Current by Moving a Wire in a Magnetic Field

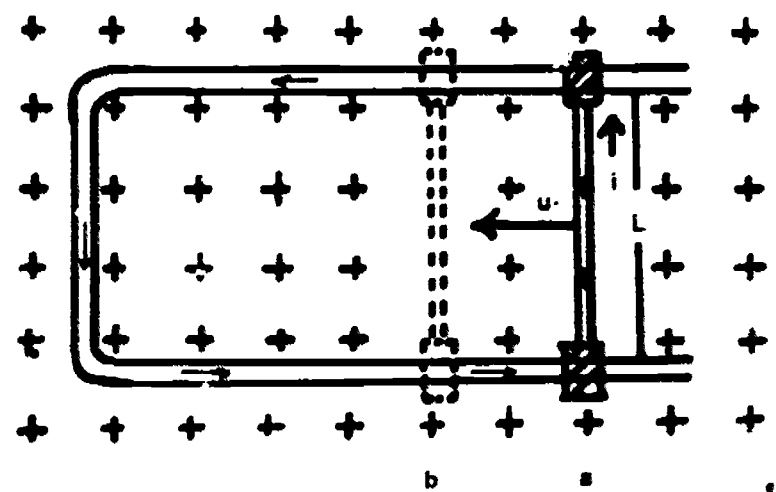

$+$'s indicate presence of magnetic field. North pole is above paper and south pole is below paper

In Figure A5-4 we change Φ by changing the area, making it smaller. Φ will change, however, when the loop of Figure A5-5 rotates in the field, for the area available to the $+$ s becomes smaller as the plane of the coil goes from a position perpendicular to the field to a position lined up with the field. In this latter position, the flux is zero since *no* arrows can go through the loop. You can perhaps visualize this if you think of one pole of the magnet as a flashlight and the other as your eye. As the loop rotates, the area enclosed by the shadow of the loop is first a maximum, then after a 90° -turn it is zero, then another 90° -turn brings another maximum, and then after 270° , another minimum.

Since the area is varying, the magnetic flux is varying, inducing (according to the physical law developed by Faraday) a potential difference, and a current will flow through the complete circuit.

It should be clear that the voltage generated by a rotating loop will alternate. It will be a maximum in one direction when the loop is perpendicular to the magnetic field, go to zero after a 90° -turn and then build back up to a maximum in the other direction after 180° , go to zero again and so on. From simple geometry, in fact, you can show that the voltage will have on average the form, $\sin \omega t$, described previously.

The rest of the generator is fairly straightforward. To connect the wire loop to an outside electric circuit for use, the ends of the wires are connected to two continuous rings which also rotate. Wire brushes at the end of connecting wires can be used to rub against the rings as they rotate, enabling the current to flow in an exterior circuit.

FIGURE A5-5
Model of an Electric Generator

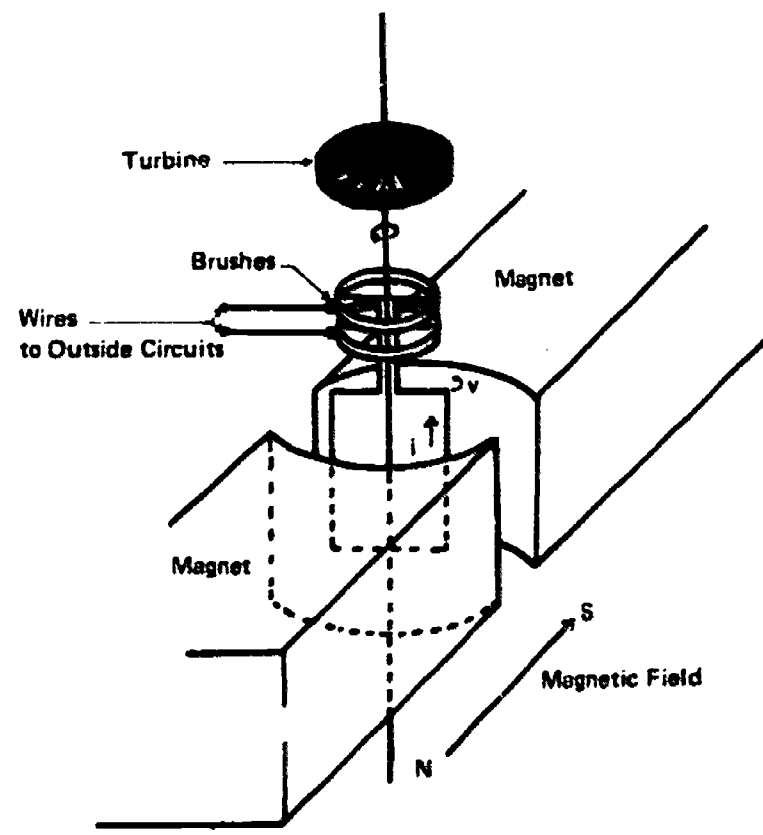

These then are the basic features of electric generators. The actual generators in use today are much more complicated devices than the one shown, but they have the same features — a series of coils that turn in a magnetic field and sliding contacts (brushes) to bring out the generated current.

The generator is only part of the system. It requires something to turn it. There are presently only two important sources of mechanical energy to turn generators — the heat engines discussed in Appendix 4 and "hydropower" from the kinetic energy of "falling" water. The heat engines dominate the picture, providing motive power for 85 percent of the generated electricity, with hydropower providing the remaining 15 percent. Of the various heat engines, the most important is the steam turbine, which generates 76 percent of the electricity. The efficiency of this conversion — thermal to mechanical to electrical — is inexorably limited by the efficiency limits on heat engines we have discussed in Chapter 3 of Volume II: electric power has to come through the "thermal" bottleneck. The emergence of nuclear-fueled generating plants will not bypass this bottleneck for, as we shall discuss in Appendix 6, nuclear energy is also converted to thermal energy. The electrical conversion in these plants will also be made by a steam turbine — generator set.

It should be emphasized that the generator itself neither stores nor produces energy. What it accomplishes, and with efficiencies close to 100 percent, is the conversion of kinetic mechanical energy into kinetic electric energy. Sitting still it is just a lump of metal.

Transmission and Distribution of Electric Power

Electricity is kinetic energy; it must move out from the generating plant, be transmitted to the consuming area, and then be distributed to individual users. Electricity is produced at 12,500 to 25,000 volts, depending on the generator. It is not transmitted at these relatively low voltages, however, for as we discussed earlier, losses due to the resistance in the transmission lines are proportional to the current squared (I^2). Electric power is thus transmitted at the highest voltages (and lowest currents) possible, as high as 765,000 volts on some transmission lines and at greater than 200,000 volts in most places.

Electric power is transmitted across the country in the familiar "high-tension lines." There are now about 300,000 miles of these lines in service across the country, and 500,000 miles are anticipated by 1990.

Transformers

The voltage has to be increased for transmission and then decreased (to 110 volts) for use. Fortunately, there is a device which accomplishes this called, appropriately enough, a "transformer."

Figure A5-6 is a schematic drawing of a simple transformer. The important components are the two sets of coils wound around opposite sides of a continuous "core" of iron. Suppose we first consider a low voltage,

— say 100 volts — applied to the side with the single coil, the "primary" winding. Current in a coil wrapped around iron sets up a magnetic field in the iron. (This is how electromagnets are built.) The magnetic field goes all around the iron core (as shown by the B lines) and, specifically, it passes through the many coils (we have drawn 10) on the other side. This is the "secondary" winding.

If the 100 volts which are applied from the left are A.C., the magnetic field in the iron varies in the same way. It starts at a maximum, goes to zero, reverses its direction, and goes to a maximum in the new direction. What will be the effect of this changing magnetic field on the "secondary" coils?

The changing magnetic field that passes through the many coils of the secondary winding produces a changing magnetic flux Φ through these coils. As a result, a potential difference is induced in each of the coils of the winding according to Faraday's law discussed earlier. Whereas the changing flux in the generator model of Figure A5-4 was due to changes in the area perpendicular to the magnetic field enclosed by the wire loop, here the area of the loop is constant but the strength of the magnetic field changes.

The origin of the changing flux in the secondary coil is the changing flux in the primary coil produced by the applied 100 volts A.C. Since the changing flux in each secondary coil must be the same, the induced potential difference, or voltage, in each turn must be equal to 100. The coils are connected, and, therefore, these potential differences (voltages) add on and the total voltage in the secondary coil is 10 times the primary voltage. The step-up in voltage, therefore, depends on the ratio of the number of coils in the secondary to the number in the primary. It should be obvious that to step voltage down, one merely works the transformer backward.

Since energy is conserved (or nearly so, since the heat losses are small), the input and output power (energy per unit time) must be the same. If the voltage changes, something else must change. The current is the only candidate. Thus, on the left we have low voltage, high current and on the right we have high voltage, low current.

FIGURE A5-6
Model of a Transformer

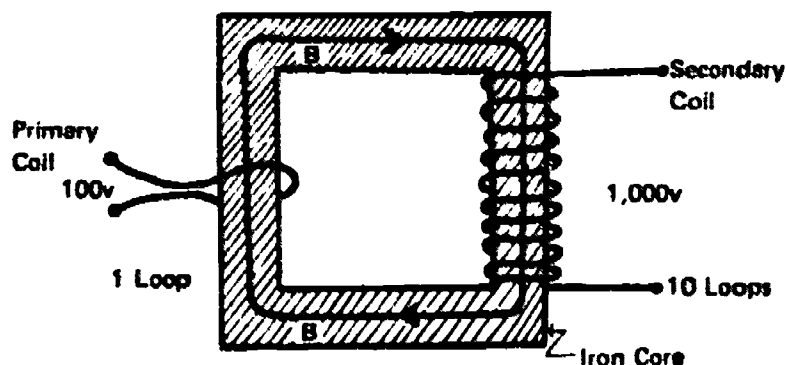

Distribution

Returning to Figure A5-3, we see that after the electric power arrives at the many transmission substations the voltage is reduced to 12,500 volts by transformers and sent out over the distribution system. Two paths are available: the wooden poles, with their insulator-dotted cross-arms, or underground cables. The distribution system is the individualized performer. It must get power to where it is needed and provide it at the right voltage and quantity to the ultimate consumer. It accomplishes this through additional voltage transformation at the point of use.

A large steel company, for example, takes its power directly from the high-voltage transmission lines and the utility company's transformer steps the voltage down to 34,000 volts. Huge amounts of power at this voltage will be used to heat electric arc furnaces for the production of steel.

For the residential consumer and the commercial customer, the voltage is stepped-down to either 120 or 240 volts (we usually refer to it as 110 and 220 volts — the actual values differ a bit from company to company). In this form it is ready for our use to power lights, appliances, and other home electric conveniences.

Electric power production and consumption is in many ways symbolic of the crises in energy and the environment. It has been, for the past two decades, the most rapidly increasing form of energy and its ready availability is the definition of "modern." In its production, from coal or oil or uranium, however, we threaten our environment in myriad ways. Description and discussion of these threads of the story of electric power occur throughout the two Source Book volumes.

SUGGESTED STUDENT ENERGY RESEARCH PROJECTS

The following projects have been suggested to stimulate student research on energy.

Projects Submitted by:

<u>COMPANY OR INDIVIDUAL</u>	<u>TITLE</u>
Procter & Gamble	a) Determining Electrical Resistivity of Wood Fly Ash b) Design & Construction of a Biomass Gasifier c) Determining Fuel Value of Various Waste Materials
Owens/Corning Fiberglas	a) The Expotential Function Applied to Natural Resource Supply and Energy Costs
SOHIO	a) The Theoretical Feasibility of Incorporating Nitrogen Fixing Bacteria in Corn b) The Optimal Conditions for Coal Drying
Owens-Illinois	a) Use of Industrial Waste Heat for Midwest Agriculture b) Gasification of Wood
James McAtee	a) Hot Air Solar Collector Experiment
American Electric Power	a) Electric Power Measurement b) Avoidance of Heated Water by Fish c) Heat Pipe Dehumidifier d) Energy Conservation for Residential Building e) Electric Power Generation, Transmission, & Distribution
Borden, Inc.	a) Liquid Heat Release Upon the Formation of a Non-Ideal Solution
Westinghouse Electric	a) Attitude Toward Energy Issues
National Rural Electric Cooperative Association	a) Demand Control

DETERMINING ELECTRICAL RESISTIVITY

OF WOOD FLY ASH

BACKGROUND

Fly ash from solid fuel boilers is often collected by means of electrostatic precipitators. These devices operate by applying an electrical charge to dust particles and passing them through an electric field where the particles are attracted to a charged collecting surface. The design and performance of precipitators are effected by the electrical conductivity of the ash particles. In practice this factor is expressed as resistivity, the inverse of conductivity. To have value to the equipment designer, dust resistivity must be measured under similar gas and temperature conditions as those at which the equipment will operate. Test data of this type is available for many varieties of coal ash. Very little information has been generated for wood ash, hampering the design of new wood-fired systems.

PROBLEM

Determine electrical resistivity of various species of wood fly ash at temperatures ranging from 200 to 800 degrees F.

REFERENCES

"Fossil Fuel Power System" by Combustion Engineering, Rand-McNally Publisher

General Power Plant Technical Literature

SUBMITTED BY Procter and Gamble Company

DESIGN AND CONSTRUCTION

OF A BIOMASS GASIFIER

BACKGROUND

Since the 1973 world oil crisis, researches have sought to find ways of using local renewable resources for fuel. Biomass, particularly wood waste and agricultural waste are available in most parts of the country. Techniques for converting these materials to a clean convenient gas form have been known for many years. Numerous process variations have been developed to produce combustible gas from wood via pyrolysis. None of the systems have come into wide commercial use, in spite of the availability and low cost of the feedstock material.

PROBLEM

Build a laboratory scale biomass gasifier from pipe and standard lab equipment, based on design concepts available from technical references. Operate the unit to determine gas characteristics and sensitivity to various forms of feedstock such as sawdust, wood chips, leaves, etc. Determine those characteristics that are barriers to commercial development of this technology.

REFERENCES

"Fuel from Waste" by Anderson and Tillman, Published by Academic Press

"Wood as an Energy Resource" by David A. Tillman, Published by Academic Press

Georgia Institute of Technology

SUBMITTED BY Procter and Gamble Company

DETERMINING FUEL VALUE **OF VARIOUS WASTE MATERIALS**

BACKGROUND

Since the 1973 world oil crisis, researchers have sought to find ways of using local renewable resources for fuel. Combustible waste materials are available virtually everywhere. Fuel value varies widely from one material to another and some materials have considerable variability within themselves, dependent on moisture content and other factors that result from how they are generated and stored.

PROBLEM

Determine heating value available from a variety of waste materials such as sawdust, grass clippings, worn out automobile tires, corncobs, etc. Establish the typical range of heating values for each material tested and compare to data on commercial fuels available in technical literature.

REFERENCES

ASTM Specification D-271
Volume 5, Section 0.05, Fossil Fuel Testing

SUBMITTED BY Procter and Gamble Company

THE EXPONENTIAL FUNCTION APPLIED TO NATURAL RESOURCE

SUPPLY AND ENERGY COSTS

BACKGROUND

Rising energy costs and dwindling natural resource supplies are two of the most important issues of our day, affecting decisions on almost every scale, from personal to national to international. One integral component in the understanding of these decisions is a good understanding of the exponential function. The exponential function is a mathematical description of anything that grows "exponentially", such as the division of a cell into two, the two into four, the four into sixteen, etc.

PROBLEMS:

1) Given the known and projected coal reserves in the state of Ohio, and the amount of electricity generated from that coal, determine the year in which the coal supplies will be exhausted, assuming annual growth rates in electrical consumption of three, five, seven and nine percent per year.

2) What if twice as much coal as expected were found next year? How long would this new supply last given the same annual growth rates in electrical consumption? How much time would be gained until exhaustion if the utilities could increase the conversion efficiencies by two percent?

3) If your family's annual energy use were to remain constant, what would their total cost for energy be in the year 2000 if energy costs rise three, five, nine, and twelve percent per year?

4) If every Ohio household could cut their energy consumption in half by employing various insulation and energy conservation measures, how long would these supplies of coal then last? Use the same assumption as in 1 and 2 above.

5) Explain the "Rule of 72".

METHODS AND RESOURCES

Much of the information you will need for this project can be gathered from your local utility. This will include values of known and projected coal supplies, coal-to-electricity conversion efficiency, and projections of residential energy consumption to the year 2000.

REFERENCES

The exponential function is explained in detail in nearly every high school algebra and pre-calculus text. An additional reference is:

Bartlett, A. A., "Forgotten Fundamentals of the Energy Crisis", American Journal of Physics, 46(9), Sept. 1978.

SUBMITTED BY Owens/Corning Fiberglas Corporation

THEORETICAL FEASIBILITY OF INCORPORATING NITROGEN FIXING BACTERIA IN CORN

BACKGROUND

The largest single item in corn production is the cost of the nitrogen fertilizer. Nitrogen fertilizer is currently produced by burning natural gas to provide the energy to convert atmospheric nitrogen to ammonia, a form that plants can use. A group of plants called legumes (soybeans and peanuts are examples) have a bacteria associated with their roots that convert atmospheric nitrogen into a form that is usable by the plant. Thus legumes do not need an external source of nitrogen fertilizer, thereby reducing the production costs for legumes. However, this nitrogen fertilizer created by the bacteria is not free in that the plant supplied all the food needs (carbohydrates) for these bacteria in exchange for fixed nitrogen. This reduces the amount of carbohydrates that are available for seed production (yield).

PROBLEM

It is possible that in the next few years, genetic engineering techniques will be sufficiently advanced to consider the feasibility of incorporating a nitrogen fixing bacteria in corn or other cereal crops (wheat and rice). Before this is done, a theoretical study should be done to answer the following questions.

1. How much yield loss will accompany the incorporation of the bacteria?
2. How does this yield loss compare with cost of nitrogen fertilizer?
3. At what price of natural gas and corn will it be economically feasible to incorporate the bacteria?

A simple computer model could be built to allow for variable costs and profits such as the cost of natural gas and the sale price for corn. This would make analyzing various possibilities easier. However this project can be done without the use of a computer. Since this project requires bringing together information from many diverse sources, the student is encouraged to contact Dr. Keener for further help.

REFERENCES

Havelka, U. D., M. G. Boyle, and R. W. F. Hardy. 1982. Biological nitrogen fixation. In; F. J. Stevenson, Ed. Nitrogen in Agricultural Soils. Agronomy Monographs No. 22.

Janick, J., R. W. Schery, F. W. Woods, and V. W. Ruttan. 1981. Plant Science, An Introduction to World Crops. Third Edition. W. H. Freeman and Co. San Francisco. pp 373-5.

Penning de Vries, F. W. T., A. H. M. Brunsting, and H. H. van Laar. 1974. Products, requirements and efficiency of biosynthesis: A quantitative approach. J. Theor. Biol. 45:339-377.

Stout. B. A. 1984. Energy use and production in agriculture. Council for Agricultural Science and Technology Report No. 99. ISSN 0914-4088.

SUBMITTED BY Dr. M. E. Keener, Corporate Research, Standard Oil Company (Ohio), 4440 Warrensville CTR, Cleveland, OH 44128

OPTIMAL CONDITIONS FOR COAL DRYING

BACKGROUND

Freshly mined coal has a high moisture content (up to fifty percent). Coal is cleaned in a process plant with more water to remove mineral matter. Some coals retain more moisture than others. The calorific value (Btu Thermal Units/pound) of moist, ash-free coal determines its value for combustion purposes. The lower the moisture content and mineral matter content the greater the value of the coal. Furthermore, shipping costs are based on the weight of coal shipped. Trains that ship coals with high moisture content are transporting large amounts of water. Therefore, it might be worthwhile to dry coal before selling or shipping.

PROBLEM

The rate of drying coal is dependent on drying temperature, particle size, the thickness and geometry of a coal pile and the pressure at which drying occurs. It is desirable to know the optimal conditions for drying coals. It is suggested that a particular size fraction of a coal is brought to equilibrium moisture (as defined by ASTM standards). Aliquots of this coal are then dried under various conditions to determine the length of time needed to remove all of the inherent moisture. Besides a coal sample, screens are needed to sieve the coal to a desired particle size. A mortar and pestle to grind the coal should be available. A vacuum dessicator, water, and potassium sulfate are needed to keep the coal at equilibrium moisture. Use a balance to weigh the coals. A timer is needed to determine the length of time between measurements. Coals should be dried at temperatures less than 100 degrees centigrade.

REFERENCES: ASTM Annual Book of Standards, Pt. 19, Gaseous Fuels, Coal and Coke, Test D1412.

Analytical Methods for Coal and Coal Products, Edited by Clarence Karr, Jr., Academic Press, 1978.

Chemistry of Coal Utilization, Edited by H. H. Lowry, Wiley, 1960.

SUBMITTED BY Dr. Alan A. Leff, Group Leader, Alternate Energy and Coal Research, The Standard Oil Co. (Ohio),
9101 East Pleasant Valley Road
Independence, OH 44131

USE OF INDUSTRIAL WASTE HEAT FOR MIDWEST AGRICULTURE

BACKGROUND

Many industries and electric utilities have low-grade waste heat available from processes which so far has been un-economical to recover. This low-grade waste heat is usually in the form of either hot water (from electric utilities) or exhaust (stack) gases from industrial processes (foundries, steel, rubber, glass, etc.) which are below 450°F. This heat is simply dissipated into the atmosphere.

One possible use for this low-grade waste heat would be to somehow utilize it in greenhouses or for hydroponic agriculture. This could extend the growing season in the midwest as well as permit growing produce which is not common to the area. Being able to grow produce, such as lettuce, melons, cucumbers, etc., in midwest winters could result in lower local consumer prices and possibly increased income to local farmers and greenhouse operators.

PROBLEM

To demonstrate and determine the feasibility of using low-grade waste heat (hot gases or hot water) in greenhouse and/or hydroponic agriculture as it applies to weather conditions in the midwest. Assume the waste heat is available year-round. How can it be used in summer, fall, winter and spring?

METHODS AND MATERIALS

A small greenhouse or hydroponic unit could be simulated using a cold-frame assembly. Waste heat could be obtained from a small oil or gas burner, from a hot water tank, closed water system using heaters, etc. Perhaps a small local industry or greenhouse operation would co-operate in providing waste heat for an experimental plot. Local or hot weather crop farming could be demonstrated throughout the cold months. The economics of the demonstration should be considered as well as the system used to deliver the waste heat.

REFERENCES AND SOURCES

- (1) "Demonstration of Beneficial Uses of Warm Water from Condensers of Electric Generating Plants." U.S. Environmental Protection Agency. EPA-600/7-80-099, May, 1980. Office of Environmental Engineering and Technology. Research Triangle Park, N.C. 2711.
- (2) Ohio Agricultural Research and Development Center. Wooster, Ohio.
- (3) "Environment Conditioned Greenhouse." Technocrat, Vol. 13, No. 4, April 1980, p. 92.
- (4) "Solar Greenhouse." Solar Energy Handbook. Amtek, Inc., Radnor, Pa. Chilton Book Co., 1979, pp. 49-54.
- (5) "Year-Round Greenhouse Works on Waste Heat." Popular Science, V 217, Oct., 1980, p. 10.
- (6) "Hydroponic Greenhouse: Plantworks." Popular Science, V 209, Nov., 1976, p. 70.

SUBMITTED BY: OWENS-ILLINOIS, INC., ONE SEAGATE, TOLEDO, OHIO 43666

GASIFICATION OF WOOD

BACKGROUND

Natural gas is not readily available in many rural areas in Ohio. Farmers and other rural residents are required to use fuel

oil, coal, electricity, propane or wood for heating purposes. Industries are reluctant to locate in rural areas particularly if they rely on gaseous fuels. Both coal and wood burning pose air pollution problems as well as disposal problems of the ash. Electricity is expensive for heating and fuel oil can be subject to disruptions from foreign supplies.

Ohio has a tremendous amount of timber, some of which has no commercial value. In addition, there is considerable scrap wood, sawdust and bark available from lumbering, construction and wood finishing operations. Could this non-commercial timber and wood scrap be used in Ohio to supply the raw materials for a biomass or wood gasification unit? And, could the gas which is produced, be used for heating, industrial use and as fuel for agricultural machinery (tractors, etc.)?

METHODS AND MATERIALS

A small gasification system could be built from pipe, scrap drums, plastic materials, etc., and various woods evaluated for their gasification capabilities. Gas flows can be measured and samples collected to be analyzed. The gas could be burned in a simple calorimeter to determine its heating value or the heating value can be determined from the gas analysis. A literature search can be used to determine the availability of wood and local wood lots could be measured and evaluated.

REFERENCES

- (1) State of Ohio Department of Development
30 E. Broad St., Columbus, Ohio 43215
- (2) National Wood Energy Association, 8400 S. Winn Rd., Rt. 3.,
Mt. Pleasant, Mich. 48858.
- (3) "A Guide to Wood Gasification". Alternate Gas Inc., 1100
Vermont Ave., N.W., Suite 410, Washington, D.C. 20005
- (4) "Steam Gasification of Forest Residues". Battelle
Publication No. 9666. Battelle Memorial Institute, 505 King
Ave., Columbus, Ohio 43201.
- (5) "Our Sawmill Runs on Wood!" Mother Earth News, V. 78,
p. 158(3). Nov-Dec 1982.
- (6) "From Biomass to Producer Gas". Design News, V 36, p.
147(3), Sept. 8, 1980.

SUBMITTED BY: OWENS-ILLINOIS, INC., ONE SEGATE, TOLEDO, OH 43666

HOT AIR SOLAR COLLECTOR EXPERIMENT

BACKGROUND:

Dramatic increases in fuel prices have focused on an international recognition that our nonrenewable resources must be conserved and wisely managed for future generations. Actions of foreign oil cartels have also provided momentum for alternative energy exploration. Solar energy is a readily available alternative for residential and commercial heating utilization.

Various experimental approaches have been examined. For example, water filled tubular collectors are attractive because of the excellent thermal characteristics of water (its ability to quickly absorb or release heat and the amount of heat that can be stored per volume). Hot air solar collectors, while not as efficient as hot water prototypes, may seem more attractive for residential heating requirements due to their simplicity and maintenance ease.

PROBLEM

Experimentally determine the heat gathering capacity of the solar collector shown (Figure 1) for various solar absorber configurations under different environmental conditions. The test setup should consist of four (4) walls resting on an insulated surface with a glass cover sheet on top. An inlet manifold to evenly distribute the air flow should be constructed from cardboard along one wall. An outlet manifold should be constructed on the opposite wall. A hair dryer or air pump could be utilized to vary the air flow rate. Instruments (such as an anemometer and a thermometer) would be necessary to measure the air flow rate as well as the air temperature at the inlet and the outlet.

The solar energy absorber placed in the space between the two manifolds could be of several configurations. For example, a series of slats (Figure 1) could be used. The number of slats, spacing between slats, slat materials, and reflective or absorbing colors could be varied. For a constant flow rate the maximum temperature increase would indicate the best performance. To compare various flow rates the weight flow rate must be used together with the temperature increase to determine the heat rate in terms of BTU's/time.

Other solar absorber configurations could be introduced for testing such as flat or tented screen materials. In fact, it would be valuable to experiment with imaginative absorber configurations in this test bed to evaluate the potential of each new configuration.

Utilizing the air flow rate and the temperature increase data it is possible to determine the heat rate in terms of BTU's/hour. This, together with the area of the collector unit, could then be used to determine the heat rate per square foot of collector area. This information could be analyzed to compare the heating ability of different absorber configurations and the air flow rates to the heating requirements of the intended residential building to determine the optimal configuration, flow rate, and size of unit.

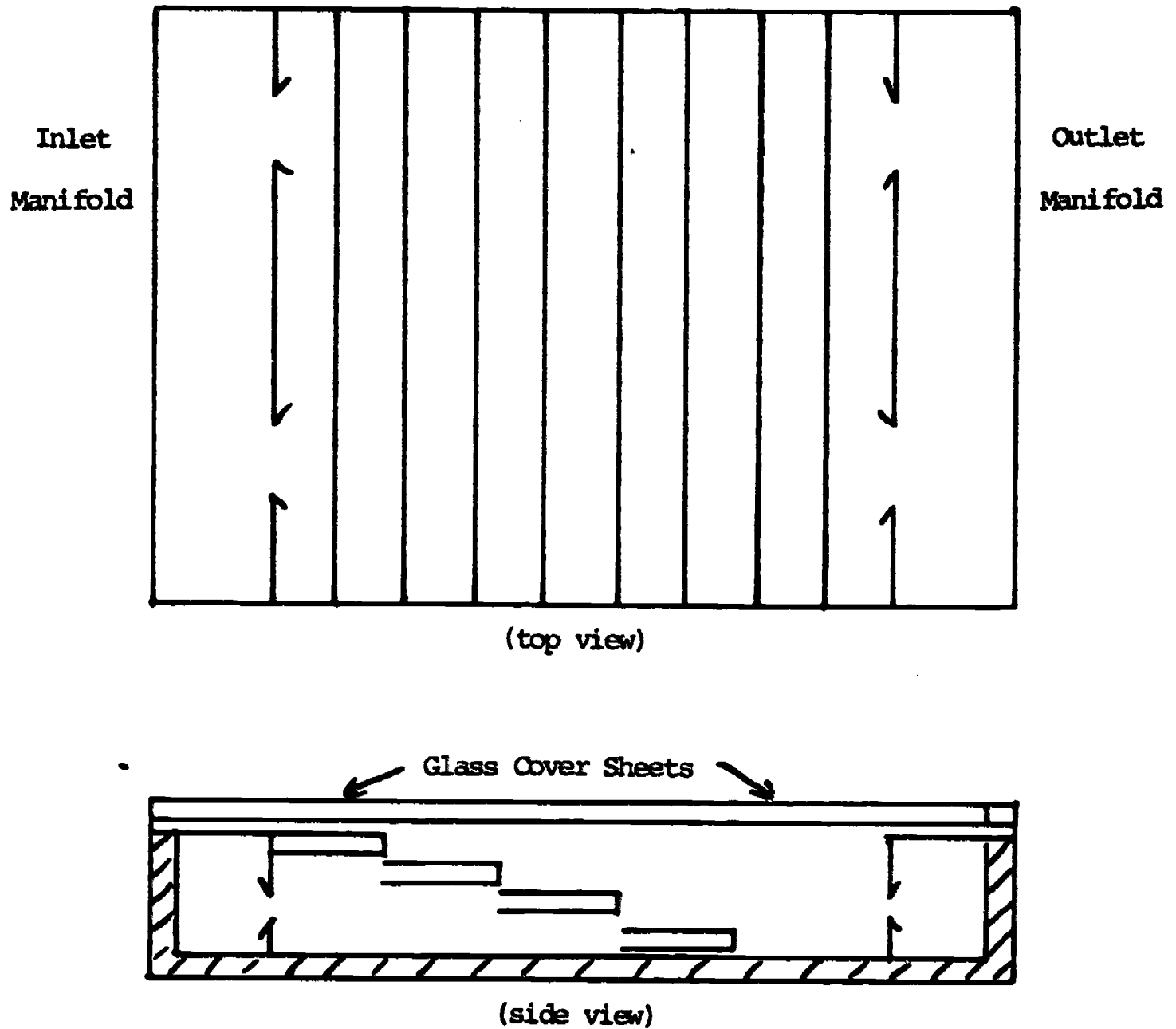

FIGURE 1. SOLAR ENERGY ABSORBER

REFERENCES

Merrill, Richard and Thomas Gage. 1978. ENERGY PRIMER: Solar, Water, Wind, and Biofuels. Dell Publishing Co. New York, NY. 256 p.

SUBMITTED BY Mr. James McAleese, CWRU

ELECTRIC POWER MEASUREMENT

BACKGROUND

Electric power, generated at one location, is distributed around the country on transmission lines to supply electrical loads where required. Electrical loads vary in type from resistive (electric heat) to inductive (electric motors) - linear (electric range) to non-linear (electric arc furnace). Of interest to the electric utility is the power into the load, the energy delivered, the efficiency of the delivery system (power line), and the harmonics generated by certain types of loads.

PROBLEM

1. Build a model transmission line to supply power to resistive inductive and non-linear load models.
2. Measure the real and reactive power into the sending end of the transmission line and at the receiving end under the various loads/Compare to calculated values from observed waveforms on an oscilloscope.
3. Calculate the efficiency of the transmission line (efficiency = Power to Load/Power into Line)
4. Determine a method to improve the efficiency of the power line when supplying the inductive load model.
5. Predict the harmonic content of the current signal and compare to the observed waveform on the oscilloscope.
6. Compute the energy delivered to the load (Power x time) and compare to the temperature rise of a styrofoam cup full of water in which the resistive load is immersed.
7. Determine the efficiency of the transformer used in the model.

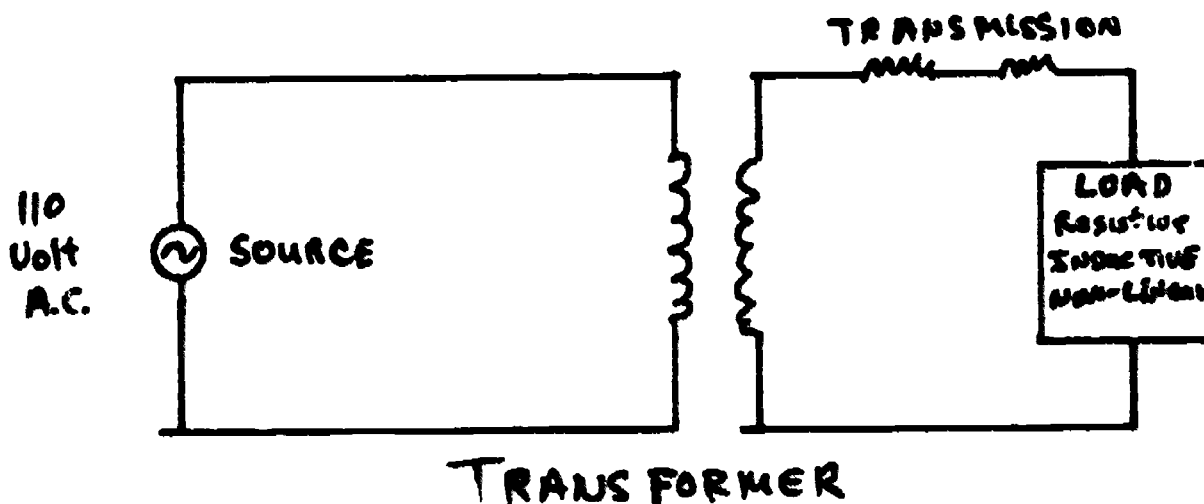

MATERIAL AND EQUIPMENT

1 - Transformer	(2:1 turns ratio),
1 - line inductor	30 to 50 mH
1 - resistor	(resistive load model)
1 - load inductor	(inductive load model)
1 - 8 volt varistor	(non-linear load model)
1 - light dimmer	(non-linear load model)
1 - oscilloscope	
1 - voltmeter	
1 - ammeter	
1 - wattmeter	

SUBMITTED BY American Electric Power Service Corporation

AVOIDANCE OF HEATED WATER BY FISH

BACKGROUND

Electricity is generated at power plants when superheated steam from boilers is released against turbine blades, turning turbine wheels at supersonic speeds. These turbine wheels on a shaft revolve huge magnets in a generator inside coils of copper wire, producing an electric current which is transmitted to consumers. The exhaust steam from the turbine is cooled in metal condensers, and the condensate is then reheated to begin the cycle again and to generate more electricity. Water to cool these condensers is sometimes pumped from lakes or rivers, and heat from the condenser is absorbed by this water. This cooling water, typically becoming 10 to 20 degrees F warmer than normal lake or river water, in some cases is discharged directly back to natural water bodies where it is cooled, initially through dilution. In other cases, this heated water is partially cooled in structures called cooling towers before it is discharged.

In the early 1970s, heated water discharged directly to natural water bodies was thought to cause great harm to aquatic organisms, particularly fish. Now, however, most scientists agree that fish survive, grow, and reproduce in the vicinity of most thermal discharges. Researchers discovered that fish can co-exist with thermal discharges because fish avoid heated water before water temperatures become lethal.

OBJECTIVES

The objective of this laboratory study is to determine the water temperature that a locally obtained fish species will avoid. Figure 1 shows some examples of lethal temperatures and temperatures at which certain fish species demonstrate avoidance.

METHODS

See Figure 2 for experimental design. Materials are listed in Figure 2. Fish are held in an aquarium of room temperature. Cool, room temperature, warm, or hot test water is released into one end of the trough, while room temperature water is released into the other end. Water temperatures at each trough is recorded. The experiment is repeated using test water of a different temperature and a new group of fish. Data should show that cumulative residence time in the test water end of the trough decreases as test water temperature increases. Results can be compared to values such as in Figure 1.

REFERENCES AND RESOURCES

- Mathur, D., R. M. Schutsky, E. J. Purdy, Jr., and C. A. Silver. 1983. Similarities in Avoidance Temperatures of Freshwater Fishes. Can. J. Fish. Aquat. Sci. 40:2144-2152.
- Cherry, D. S., and J. Cairns, Jr. 1982. Biological Monitoring: Part V - Preference and Avoidance Studies. Water Res. 16: 263-301.
- Cairns, J., Jr., D. S. Cherry, and S. R. Larrick. Fall 1979. Thermal Discharge Research. Water Spectrum. pp. 1-8.
- Cherry, D. S., K. L. Dickson, and J. Cairns, Jr. 1976. Preferred, Avoided, and Lethal Temperatures of Fish During Rising Temperature Conditions. J. Fish. Res. Bd. Can. 34: 239-246.
- Cherry, D. S., K. L. Dickson, and J. Cairns, Jr. 1974. The Responses of Fish to Heated Water Discharges. Aware 51: 13-15.

CONTACT

Paul Loeffelman, AEPSC, Environmental Engineering Division, 1 Riverside Plaza, Columbus, Ohio 43216. (614) 223-1234.

Dr. Donald Cherry, Center for Environmental Studies, Virginia Polytechnic Institute and State University, Blacksburg, Virginia 24061

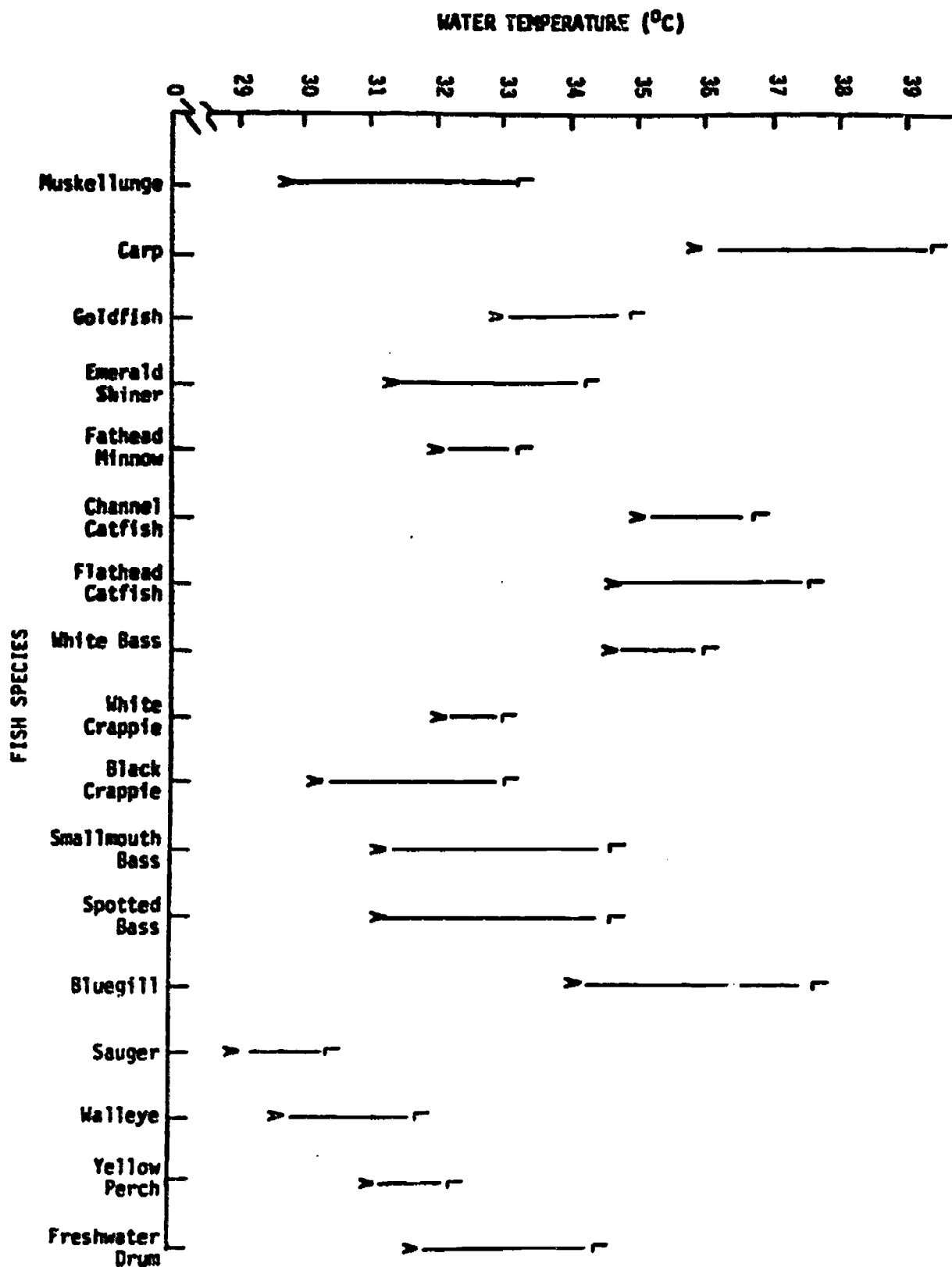

Figure 1. Summer Avoidance (A) and Lethal (L) Temperatures for Selected Fish Species (Source: Ohio EPA Data Contained in 1977 Rationale Documents for Revising Ohio Water Quality Regulations; Data Plotted by Amer. Elect. Pwr.

EQUIPMENT

- 1, 4' trough deep enough for 3" water depth and ≥ 3 " wide closed ends.
- Inside painted uniform color, non-reflective.
- 3" standpipe at center of trough.
- 4, aquaria, carboys, or other reservoirs of ≥ 5 gallons.
- 2, rubber or plastic hoses or tubing long enough to reach from reservoirs to bring water by gravity to the trough.
- 2, screw clamps to regulate water flow through hoses.
- 3, airstones with air source and tubing.
- 1, hot plate.
- 1, thermometer.
- 1, stopwatch or watch with second hand.
- 1, laboratory notebook and pencil.
- 1, large beaker for heating water.
- ice.
- 20-30 fish of one species, 4" long.
- 4 nozzles to attach hoses to ends of trough and to reservoirs.

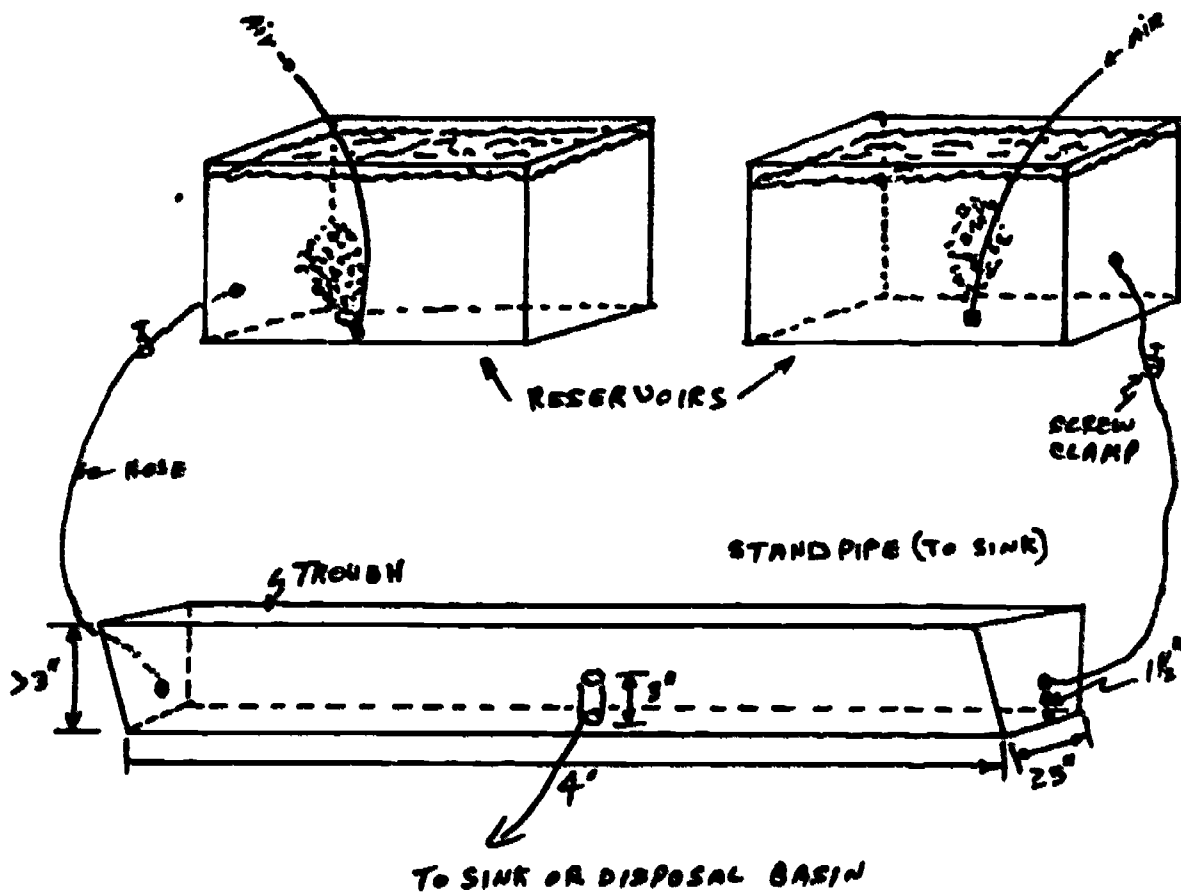

Figure 2. Experimental Design for Avoidance Tests
(Source: Amer. Elect. Pwr. Serv. Corp.)

SUBMITTED BY American Electric Power Service Corporation

HEAT PIPE DEHUMIDIFIER

BACKGROUND

High humidity in basements is a common problem to homeowners. Evidence of this condition is usually manifested by musty smells and water condensation on cold water pipes.

Typically, homeowners purchase dehumidifiers to remove the moisture from the basement air.

PROBLEM

A heat pipe is a passive system which moves energy between two points operating at different temperatures. Basically, the pipe operates at the vapor pressure of the working fluid (Freon, ammonia, etc.) within the pipe and transmits energy by vaporizing the fluid from the hot end and condensing the gas on the cold end of the pipe. The condensing liquid drains back to the hot end and the process continues.

The ground surrounding a home is at a relatively stable temperature of approximately 50 - 55 degrees F. A suitable working fluid for a heat pipe system to dehumidify a basement could be determined and experimentally tested to determine its performance.

METHODS AND MATERIALS

Using finned copper tubing available from a heating & ventilation supplier, construct a heat exchanger using your proposed design. For demonstration purposes, the ground coil could be immersed in a tank of cool tap water. The school's automotive department should have adequate equipment to charge the system and its instructors should monitor the charging of the system to insure proper care is taken.

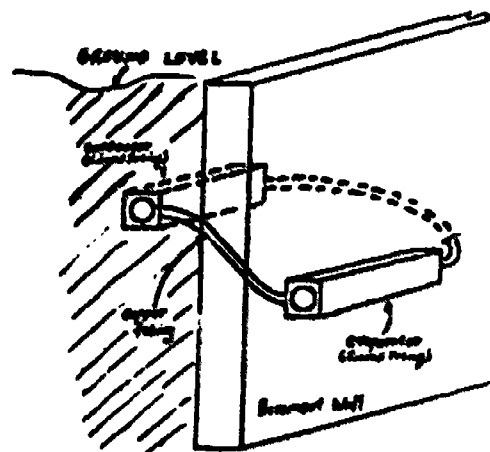
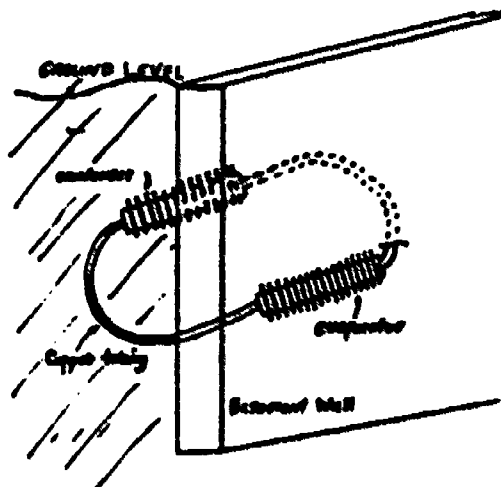

REFERENCES

ASHRAE Handbook - Fundamentals

SUBMITTED BY American Electric Power Service Corporation,
Analytical and R&D Section

ENERGY CONSERVATION FOR RESIDENTIAL BUILDING

BACKGROUND

It is possible to reduce residential energy use by 25 percent by proper design and insulation of building with little or no change in our standard living. Unfortunately, the residential homes built prior to 70's neither have adequate insulation nor can they be economically modified for effective or efficient use of electricity. However, many innovative systems could be developed for residential use.

PROBLEM

Develop a simple system for heat recovery (extraction) from an average residential home during summer and use that heat effectively for other residential use such as water heating (hot water system). This would not only keep the home cooler during summer, but without or with considerable lower load on air conditioning system.

Assumptions:

Average Summer Temp.	87 F
Average Room Temp. after Heat Extraction	77 F
Hot Water Temp.	140 F
City Cold Water Supply Temp.	65 F
Water Consumption/day	125 gal
Hot Water Consumption (including dishwasher & washing machine)	75 gal
Average Area of Home	1200 sq. ft.

REFERENCES

Any Basic Thermodynamic Book Heat Transfer & Thermodynamics
- M. Zemansky, McGraw-Hill Publication.

Contact American Electric Power Service Corporation,
Analytical and R&D Section, 1 Riverside Plaza, Columbus, OH
43215

SUBMITTED BY American Electric Power Service Corporation

ELECTRIC POWER GENERATION, TRANSMISSION, AND DISTRIBUTION

BACKGROUND

Our daily lives revolve around the use of an extremely important commodity called electricity. Electricity is required in homes as well as in the industry. Without electricity industrial production will cease, all motors will come to a standstill, no refrigerators or television would work, all street and home lighting will be turned off, and in short, the lifestyles of our society will be completely disrupted. The purpose of this project, therefore, is to understand and demonstrate a means of converting one form of energy to another and apply this knowledge to the process of generating, transmitting, and distributing electric power. It is left to the researcher to identify and utilize whatever form of raw energy (i.e., hydro, coal, or solar) that is required for this project. For example burning coal produces heat. This heat is used to convert water into steam. The steam drives a turbine. The turbine drives a generator which produces electric power. Power is then transmitted through conductors to serve the electric load.

PROBLEM:

Design and build an alternating current electric power system to supply a 100 watt load. Examine the impact of variations in power supply frequency on the load. Evaluate methods to maintain a constant frequency. Examine the impact of a sudden loss of load on the generating unit.

METHODS AND MATERIALS:

Some of the materials necessary for this project are provided in the reference cited below.

REFERENCE:

"Electricity Made Simple", Made Simple Books, Doubleday and Company, Inc., Garden City, N.Y. (Additional references are cited in this book.) The researcher may contact the person named below for technical matters relating to this project.

SUBMITTED BY

**Dr. Nadipuram (RAM) R. Prasad, Assistant Section
Manager, Technical and Special Studies
Section, Bulk Transmission Planning Division,
AEP Service Corporation, 1 Riverside Plaza,
Columbus, Ohio 43215, Phone (614) 223-2355**

**LIQUID HEAT RELEASE UPON THE FORMATION
OF A NON-IDEAL SOLUTION**

**+++ EXTREME CAUTION MUST BE USED IN HANDLING ACIDS +++
DO NOT ADD WATER TO ACID
CONDUCT THIS EXPERIMENT ONLY UNDER SUPERVISION
USING STANDARD LABORATORY SAFETY PRECAUTIONS**

BACKGROUND:

The Laws of Conservation of Mass and Energy can be used to characterize many complicated systems. One such system would involve the mixing of dissimilar liquids. Heat is generated when non-ideal solutions are formed. The heat is a result of molecular interaction and physical reaction. Therefore, certain types of pure liquids can be used to store heat at room temperature. When heat at an elevated temperature is needed, they can be mixed to release heat. When excess energy from another system is available, the solution liquids may again be separated into pure liquids and stored for reuse. This type of system enables the capture and utilization of wasted energy.

STATEMENT OF PROBLEM

To determine the heat release (exothermic) of mixing strong (inorganic) acid into water.

METHOD AND MATERIALS

Take 25 ml of 18 N sulfuric acid and mix it slowly into 25 ml of pure water. The mixing can be done in a beaker or Dewar flask using a glass thermometer as a stirrer. With 18 normal sulfuric acid and 25 ml each of water and sulfuric acid, the resulting temperature will be 115 to 125 degrees C after one-half minute of mixing. Other acids can be used in place of sulfuric and various amounts of acid may be added to the water, but caution should be present in handling the acid especially when adding it slowly to the water.

The methodology for determining the heat release is contained in the ILLUSTRATION. For further study, develop ideas

on how the acid and water may be re-separated and what overall efficiency various non-ideal solution/solution separation systems would have.

REFERENCES AND RESOURCES

Franke, Herbert W., The Magic of Molecules, Abelard-Schuman, Chapter 13, p. 176.

Kalbus, Lee H., Kenneth A. Mantel, and Ralph H. Petrucci. 1983. A Laboratory Demonstration of the Conservation of Energy. Journal of College Science Teaching Volume 12: 277-278. Feb. 1983.

Klotz, I.M., Chemical Thermodynamics, Englewood Cliffs, NJ, Prentice-Hall, Inc., Chapter 14, p. 205.

Perry, Robert H. & Cecil H. Chilton, Chemical Engineers' Handbook, Fifth Edition, NY, NY, McGraw-Hill Book Co., pp. 3-22, 3-24, 3-129 and 3-135.

Pribula, Alan J., Introduction to Chemistry in the Laboratory, NY, NY, McGraw-Hill, Inc., pp. 43, 65, 145 and 153.

ILLUSTRATION

Mass and Energy Balances: Solution Heat Generation Determination

Mass Balance: Acid Weight + Water Weight = Solution Weight

Energy Balance: Heat Input + Generation = Heat Output

Term Definitions

Acid Weight: $M_A = \text{ml} \times \text{specific gravity acid, grams}$

Water Weight: $M_W = \text{ml} \times \text{specific gravity water, grams}$

Solution Weight $M_A + M_W, \text{ grams}$

Heat Input: Specific heat_W $\times M_W \times (T \text{ water ambient} - T \text{ ref.})$
+ Specific heat_A $\times M_A \times (T \text{ acid ambient} - T \text{ ref.})$

Where: Specific heat = C_{PA} or $C_{PW}, \frac{\text{cal}}{\text{gram} \text{ } ^\circ\text{C}}$

$T \text{ water ambient} = \text{normal room temperature, } ^\circ\text{C}$

$T \text{ acid ambient} = \text{normal room temperature, } ^\circ\text{C}$

$T \text{ ref.} = \text{Base reference temperature for heat calculation, } ^\circ\text{C}$

Generation: $H_g = \text{difference in heat output less heat input as calories in above equation, cal}/(M_A + M_W)$

Heat Output: Solution specific heat $\times (M_W + M_A) \times (T \text{ measured} - T \text{ ref.})$

Where: Solution specific heat = $\frac{(M_W \times C_{PW} + M_A \times C_{PA})}{M_W + M_A}, \frac{\text{Cal}}{\text{gram} \text{ } ^\circ\text{C}}$

$T \text{ measured} = \text{Maximum resulting soln. temperature, } ^\circ\text{C}$

Pure liquid specific gravities, specific heats and other general information on the heat of solution can be found in the example references. The mass and energy balances reduce to:

$$H_g = (C_{PW} \times M_W + C_{PA} \times M_A) \times (T \text{ measured} - T \text{ ambient}),$$

cal per $(M_A + M_W)$ grams of solution

($T \text{ ref.} = T \text{ ambient}$)

($T \text{ water ambient} = T \text{ acid ambient}$)

SUBMITTED BY: Borden Inc, Science & Technology Department,
165 North Washington Avenue, Columbus, OH 43215

ATTITUDE TOWARD ENERGY ISSUES

BACKGROUND

Solutions to problems in a democracy like the United States of America require an understanding and supportive electorate. Whether the approach is private or public, ultimately the consumer will help resolve our energy problems by individual choices made in lifestyle and through voting preferences.

Knowing what people think -- their opinions -- helps both private corporations and governmental agencies plan for solutions to problems. Opinions change over the years. Hence it is important to survey attitudes from time to time to determine the public mood and understanding of certain issues like energy and energy conservation.

PROBLEM

Design a survey using the following questions or ones that you make up yourself. Administer the survey in your own community. Determine what effects such factors as age, employment status, and lifestyle have on the results. Compare your results with national surveys that may be available.

REFERENCES

Kuhn, D. J. 1980. The Development and Application of an Energy Questionnaire. Journal of Environmental Education. Volume 11:25-28.

Moneim, Abdel and Ahmed Hassan. 1984. Designing a Likert Scale to Measure Chemistry Attitudes. School Science and Mathematics Volume 84(8): 659-669. December 1984.

QUESTIONNAIRE

Directions

Read each numbered statement below. As an indicator of your attitude or feeling about the issue in the statement, please "circle" the appropriate response. The key is as follows:

SA = Strongly Agree
A = Agree
U = Undecided
D = Disagree
SD = Strongly Disagree

-
- | | | | | | |
|--|----|---|---|---|----|
| 1. There is no energy crisis. | SA | A | U | D | SD |
| 2. The automobile is my preferred means of transportation. | SA | A | U | D | SD |
| 3. Rationing gasoline is the best way to solve the energy crisis. | SA | A | U | D | SD |
| 4. Only governmental regulation can "force" solutions to the energy crisis. | SA | A | U | D | SD |
| 5. Big business created the energy crisis "scare" in order to raise prices. | SA | A | U | D | SD |
| 6. Adults should be willing to make sacrifices to conserve energy. | SA | A | U | D | SD |
| 7. In our country, coal should be burned to produce energy. | SA | A | U | D | SD |
| 8. Storing nuclear waste is not a problem. | SA | A | U | D | SD |
| 9. Oil is such a valuable source of petrochemicals that it is too precious to be burned as a fuel. | SA | A | U | D | SD |
| 10. Mass transportation should be developed to save fuel. | SA | A | U | D | SD |
| 11. Breeder reactors provide nuclear material that is a threat to national security. | SA | A | U | D | SD |
| 12. Electrical power needs in the nation must increase. | SA | A | U | D | SD |
| 13. Private industry is not concerned with ways to find new sources of energy. | SA | A | U | D | SD |
| 14. We should not depend on foreign nations for energy resources. | SA | A | U | D | SD |
| 15. Energy education should be taught in all subject areas. | SA | A | U | D | SD |

- | | |
|--|-------------|
| 16. The energy sources we now have available are all that are needed. | SA A U D SD |
| 17. Oil companies are not concerned with ways to find new sources of oil to solve the energy crisis. | SA A U D SD |
| 18. Industry should be required to "cut back" on energy before the general public. | SA A U D SD |
| 19. Energy education should be taught at each grade level. | SA A U D SD |
| 20. The general public has conserved less energy than private industry. | SA A U D SD |
| 21. Nuclear reactors should be built to provide electricity. | SA A U D SD |
| 22. To improve our life style in the U.S., the amount of energy that is used must increase. | SA A U D SD |
| 23. Private industry will develop the "newer" energy technologies when it is monetarily profitable. | SA A U D SD |
| 24. A politician's voting record on energy issues should be made public. | SA A U D SD |
| 25. To save jobs and increase employment, environmental standards should be relaxed. | SA A U D SD |
| 26. Federal programs rather than private industry initiative should be initiated to develop new energy sources. | SA A U D SD |
| 27. Utility companies should encourage energy conservation by consumers through the use of differential rate structures. | SA A U D SD |
| 28. Adequate information is available for me to develop an energy curriculum for my grade level. | SA A U D SD |
| 29. Radiation hazards can be minimized using current/existing technology in the nuclear industry. | SA A U D SD |
| 30. Pollution can be minimized using current/existing technology in the fossil fuel generation of electricity. | SA A U D SD |

SUBMITTED BY Westinghouse Electric Corporation

DEMAND CONTROL

BACKGROUND AND STATEMENT OF PROBLEM

One of the problems today's utilities are confronting is a decrease in their load factor. The definition of load factor is the ratio of the peak kilowatt demand to the average demand during a certain time interval (i.e., a day). We find that in many rural areas (where there is little commercial industrial load to help moderate) energy conservation measures and working couples have led to pronounced peak demands in the morning and in the evening with minimal requirements in the middle of the day and night. The result is that the rural electric power suppliers are not fully utilizing their cheap, efficient coal fired generating plants (which have to be run at a steady level and cannot follow this roller coaster pattern) and are having to buy or generate expensive "peaking" power from gas turbines.

We have been doing considerable research on ways to avoid this expensive situation. The new approach that has been developed is called demand management and it involves the use of microprocessor or communications equipment to communicate with the major residential loads (water heater, electric furnace/air conditioner, clothes dryer, refrigerator, and electric range) and control the coincidence of their demand upon the utility system.

Our rural electric systems in Ohio, represented by Buckeye Power, Inc., in Columbus, have an extremely progressive statewide system where they are controlling over 50,000 electric water heaters (which can be switched off at "peak" times with little inconvenience to the consumers involved) by radio communications equipment planted on the water heater in the consumer's home.

The other approach, using microprocessor-type equipment, is much less commonly utilized (but extremely interesting and perhaps equally as promising). It involves the installation of a decision-making microprocessor or electro/mechanical device, which senses the current flowing into the household and is set to trip out appliances in a prescribed order should the household load exceed the proscribed level. The order of appliance trip is typically: water heater, electric space conditioning (heating and/or air conditioning), refrigerator, electric clothes dryer and, finally, electric range. The order represents the increasing level of inconvenience to the consumer of the interruption of service to that appliance.

RESEARCH PROJECT SUGGESTION

We would recommend that an excellent science research project would be to build a scale model of a house with miniature appliances with lightbulbs inside to indicate whether they are on

or off. You could show how this concept works and the impact on household electric demand and appliance operation by installing one of these demand control devices and demonstrating the switching sequences and savings to the utility.

One of our staff members, Wilson Prichett, Research Engineer (202/857-9795), can help you with this concept if you are interested.

SUBMITTED BY: NATIONAL RURAL ELECTRIC COOPERATIVES ASSOCIATION

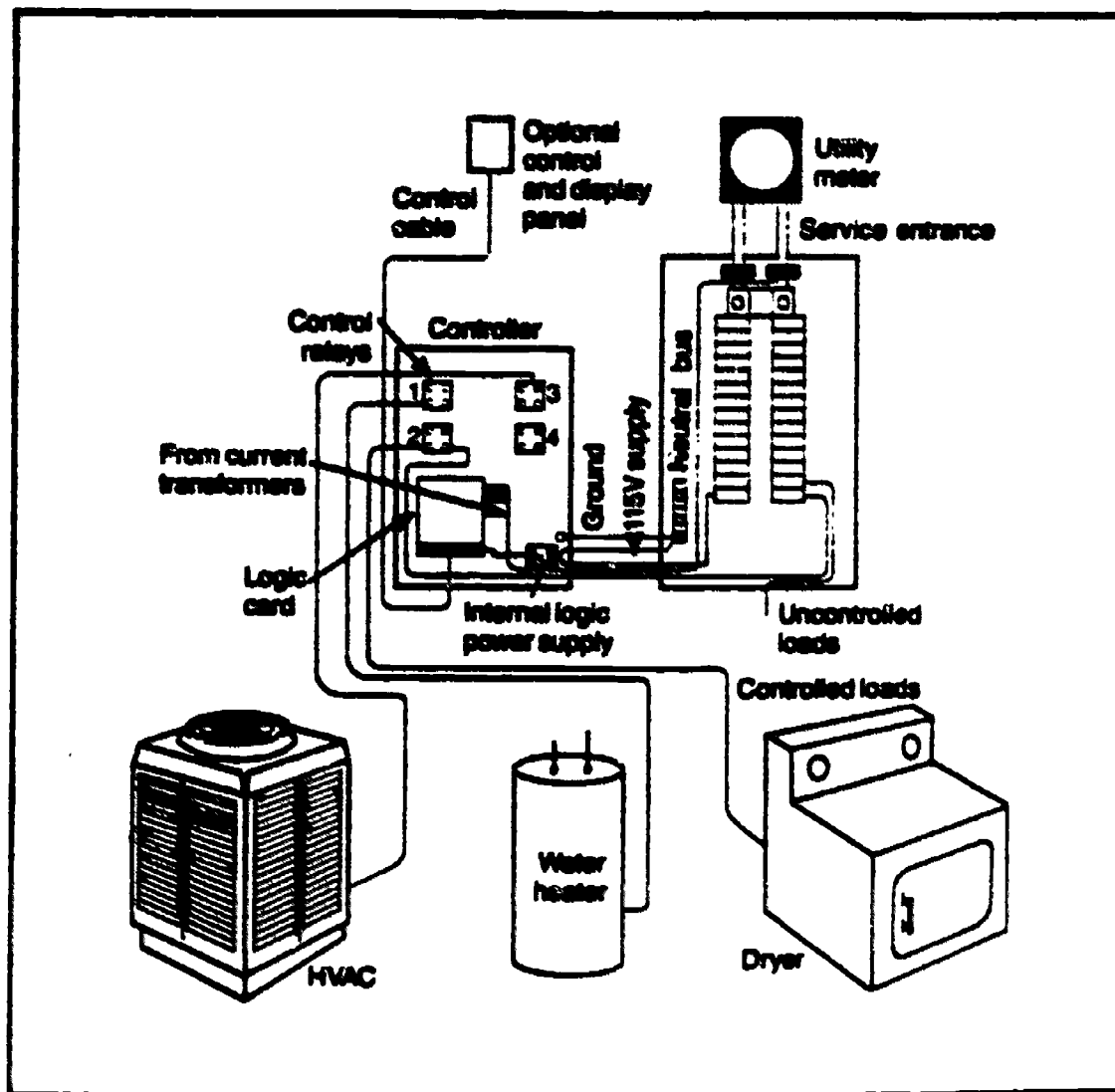

BEST COPY AVAILABLE

HOW TO FIND ENERGY INFORMATION IN YOUR LIBRARY

Sorting through the maze of publications and information sources on energy is difficult work. A serious error of first time researchers is trying to do too much. You'll be able to do a better job if you narrow your topic.

For example, if you've chosen energy as a general area of research, and if you've formulated a question or problem, you need to understand that information can be broken down into smaller units. Soon you'll reach an area that is limited enough to allow you to proceed until you have exhausted the available sources of information.

The broad topic of energy may be divided into

- sources,
- uses, and
- the physics of energy.

Sources may include natural gas, oil, nuclear, coal, solar and wind. If you are particularly interested in wind you'll soon discover that you can be even more specific.

Projects on wind may be concerned with availability, economics, environmental aspects, regulations and engineering.

Engineering may be limited to the problem or question of:

"How will blade design affect performance of a wind turbine?"

The following diagram illustrates the concept of narrowing the topic.

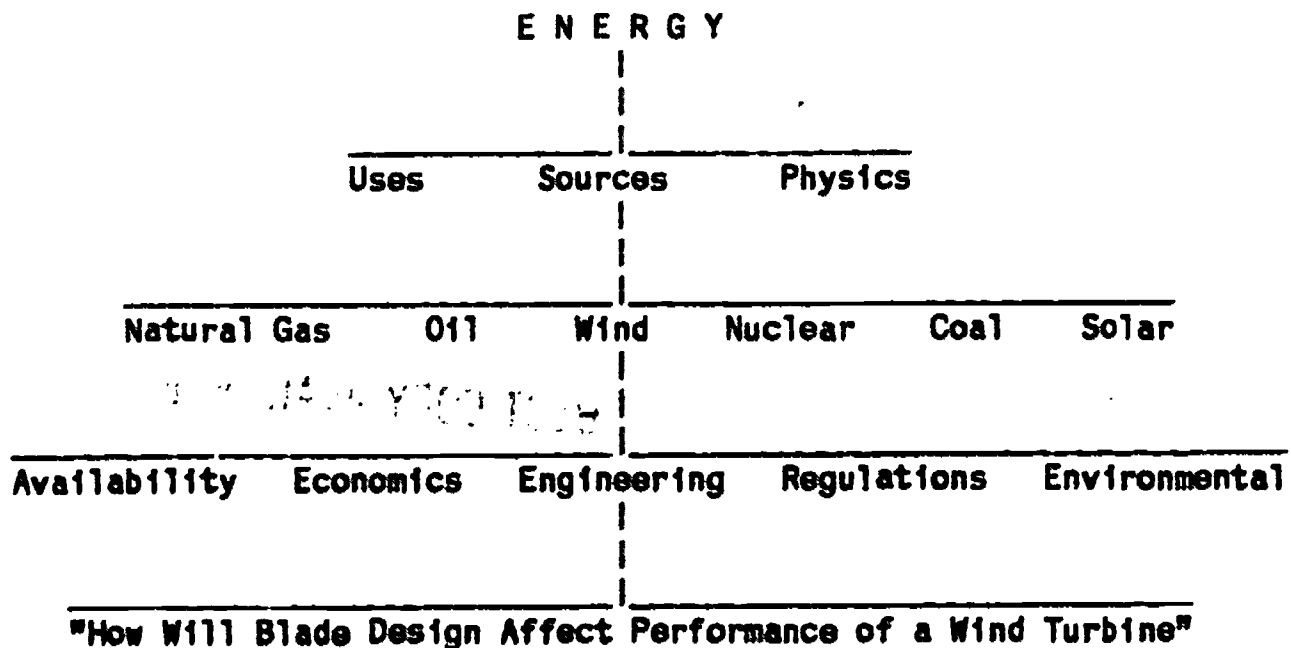

To help orient you further to the concept of narrowing the topic and to stimulate ideas for research topics, we have reproduced on the next three pages the Subject Contents of the publication Energy Research Abstracts. You'll note 40 first-level and 293 second-level subject categories. Many of the second-level subject categories are still too broad for student research projects and will require further work to narrow them.

Let's look at how you might use your local library to find more information. Although advanced research requires access to university and research libraries, you'll find that your local library will give you access to a world of information if you'll only ask.

CARD CATALOGUE

The first stop in the library will probably be the card catalogue. Here you'll find, arranged by author, title, and subject, a complete listing on cards of the books available in the library. Some libraries now have computer terminals with "on-line" catalogues which may be searched rapidly for publications related to your topic. These "on-line" catalogues often are useful to find publications which, although not in the library you are visiting, may be borrowed from other libraries through inter-library loan. The card catalogue will list circulating books, which are usually stored on long rows of shelves or stacks. You can also use the card catalogue to find non-circulating reference books.

REFERENCE BOOKS

Reference books include science encyclopedias which can be used as a starting point in your research to get an overview of the subject. A top quality research project, however, must use many other sources of information since encyclopedias are general and seldom are useful beyond the early stages of your work.

Handbooks of standards, formulas and data will be helpful in determining whether your results are similar to those obtained over the years by other reserachers. Handbooks also provide information on mathematical conversions and basic chemical and physical science data such as constants and properties of materials.

INDICES

Newspaper, magazine and journal indices give you access to a broad range of publications. Nearly every library will have the Readers Guide to Periodical Literature which allows you to find articles in popular publications. Often, the library will have a copy of the publication or the library may have a microfilm or microfiche copy for viewing and copying in a special reader. One of the most exhaustive indices is Current Contents, a weekly publication which reproduces the "contents pages" of thousands of journals and provides subject and authors indices.

ABSTRACTS

Abstract publications provide extensive listings of research reports and technical papers presented at meetings or published in scientific and engineering journals. Although not always available in many local libraries, most college libraries have abstract publications on energy, the environment, chemistry, physics, mathematics, and social sciences. Each April The Ohio Journal of Science publishes nearly 350 abstracts of papers presented at the Annual Meeting of The Ohio Academy of Science. Reproduced below are the instructions from Energy Research Abstracts to show you what to expect when searching abstract publications:

HOW TO USE ENERGY RESEARCH ABSTRACTS

ABSTRACTS IN ENERGY RESEARCH ABSTRACTS

The principal elements of abstract entries for a typical research and development report and a typical technical journal article are illustrated below.

Report number	Date of publication	Contract number
Availability	Author(s)	Title
24582 (LA-8830-MS)	Urban, W.T., Seed, T.J., Dudrik, D.J.	Nucleonic analysis of the ETF neutral-beam-injector-duct and vacuum-pumping-duct shields.

(Los Alamos Scientific Lab., NM (USA), May 1981, Contract W-7405-ENG-36, 82p. NTIS, PC A05/NE A01, Order Number DE81023986.

A nucleonic analysis of the Engineering Test Facility neutral-beam-injector-duct and vacuum-pumping-duct shields has been made using a hybrid Monte Carlo/discrete-ordinates method. This method used Monte Carlo to determine internal and external boundary surface sources for subsequent discrete-ordinates calculations of the neutron and gamma-ray transport through the shields. Confidence was provided in both the hybrid method and the results obtained through a comparison with three-dimensional Monte Carlo results.

Journal citation	Date of publication	
Author(s)	Title	
24033 (Ben Gurion Univ. of the Negev, Beer Sheva, Isr.)	1981	Empirical prediction of bubble diameter in gas fluidized beds.

(Ben Gurion Univ. of the Negev, Beer Sheva, Isr.) *International Journal of Multiphase Flow*, V. No. 1, 101-113 Feb 1981.

Theoretical expressions for bubble diameter in both small and large particle fluidized beds are derived by the application of two phase theory and gas flow continuity. Comparison with experimental data suggests that the numerical and analytical solution of these expressions, combined with empirical bubble frequency relations, can provide an accurate prediction of bubble size and its parametric trends. 25 refs.

INDEXES TO ENERGY RESEARCH ABSTRACTS

Five indexes are provided for approaching the contents of each issue of *Energy Research Abstracts (ERA)*. Each index is preceded by an introduction that details the organization of the index and the principles by which it was compiled. The reader is referred to these introductions for information not found in the index examples that follow.

• Corporate Author Index

Technical report literature is indexed using the name of the organization or institution responsible for the issuance of the report.

24582 (LA-8830-MS) Nucleonic analysis of the ETF neutral-beam-injector-duct and vacuum-pumping-duct shields. Urban, W.T., Seed, T.J., Dudrik, D.J. (Los Alamos Scientific Lab., NM (USA), May 1981, Contract W-7405-ENG-36, 82p. NTIS, PC A05/NE A01, Order Number DE81023986.

is indexed as:

Los Alamos Scientific Lab., NM (USA)

Nucleonic analysis of the ETF neutral-beam-injector-duct and vacuum-pumping-duct shields, 6-24582 (R-US)

• Personal Author Index

Each author's name is indexed in the form appearing on the document abstracted, with the exception that given names are reduced to initials:

Bar-Cohen, A., Semiempirical prediction of bubble diameter in gas fluidized beds. 7-24033 (IJS)

Dudrik, D.J., See Urban, W.T., 6-24582

Gluckman, L.R., See Bar-Cohen, A., 7-24033

Hughes, R.W., See Bar-Cohen, A., 7-24033

Seed, T.J., See Urban, W.T., 6-24582

Urban, W.T., Nucleonic analysis of the ETF neutral-beam-injector-duct and vacuum-pumping-duct shields, 6-24582 (R-US)

• Subject Index

The subject index consisting of entries naming specific materials, objects, and processes is arranged alphabetically. Document titles, informative phrases, or both specific to these entries are arranged alphabetically under the entries.

TOKAMAK ETF

Neutral Atom Beam Injection

Nucleonic analysis of the ETF neutral-beam-injector-duct and vacuum-pumping-duct shields, 6-24582 (R-US)

Neutron Transport

Nucleonic analysis of the ETF neutral-beam-injector-duct and vacuum-pumping-duct shields, 6-24582 (R-US)

• Contract Number Index

DOE technical literature is indexed using contract numbers under which the literature was produced. This index contains the contract number with corresponding abstract and report numbers.

W-7405-ENG-36 Los Alamos National Lab., NM (USA)
6-24582 LA-8830-MS

• Report Number Index

Technical report literature is also indexed using report numbers. This index includes information on where individual reports may be obtained. Patents and conference papers are indexed here as a matter of convenience. When a report is supplied under an Order Number, that number is included in the availability statement. An Order Number-Report Number Correlation is included for convenience.

LA-8830-MS 6-24582 NTIS, PC A05/NE A01, Order Number DE81023986, Distribution Category STD-206

BEST COPY AVAILABLE

VERTICAL FILE

The vertical file, sometimes called pamphlet file, often contains useful information not found by other means. Here you'll find publications from state and Federal agencies, corporations, trade and professional groups. The materials are usually arranged by subject and filed in large folders.

ADDITIONAL REFERENCES AND SOURCES OF INFORMATION

SOME GROUND RULES

In this section we have listed references and sources of information to enable students to go as far as they would like to in seeking detailed and specific information on energy. This section is based on the first-level subject categories of Energy Research Abstracts published by the U.S. Department of Energy.

Before encouraging students to contact these sources it is imperative that teachers give students some ground rules:

1. Be sure that students have written proposals or research plans for their projects including specific problems or objectives.
2. Students should exhaust local library resources first. Too often students write or call corporations, governmental agencies and institutions without first "doing their homework."
3. Instruct students to write letters which request specific information and not everything under the sun. Two examples follow:

Unacceptable Letter

Mr. J.D. Smith
Director of Public Information
XYZ Corporation
Anytown, OH 43215

Dear Mr. Smith:

I am doing a science project on energy. I don't know anything about this subject, so will you please send me everything you have on the subject.

I need to finish my project by Friday, so would you please hurry?

Sincerely,



Bill Smith

P.S. My friend Sally is doing her project on guppies. She asked me to ask you for information on guppies too.

This is a weak letter for the following reasons:

1. No date
2. No inside address for return of information
3. Request is too general; asks for everything under the sun
4. Student has not narrowed the topic
5. Student has not exhausted local library sources first
6. Response time (by Friday!) is too short
7. The student should not ask questions for someone else, especially when they are unrelated (guppies?)

Acceptable Letter

**William Smith
123 Smith Street
Smithton, OH 12345
(419) 333-4444**

October 1, 1985

**Mr. J. D. Smith
Director of Public Information
XYZ Corporation
Anytown, OH 43215**

Dear Mr. Smith:

I am doing a student research project on how blade design will affect performance of a wind turbine. I have exhausted the resources at my school library, the local public library, and the nearby college library. I have also corresponded with Dr. G. F. Lox at the University of Denver.

Knowing that the XYZ Corporation has produced wind turbines for many years I thought that you may be able to help me locate recent test data on the how blade design affects performance of wind turbines. Do you have any recent reports or data which you could share with me? Is there someone at XYZ Corporation who would be willing to talk with me about this request?

To help you respond to my questions I have enclosed my research plan and a summary of the information I have collected.

Thank you for your consideration of my request.

Sincerely,

William Smith

William Smith

Enclosure

This letter is more acceptable for the following reasons:

1. Includes return address, phone number and date
2. Student shows evidence of using local library resources

3. Request is more specific than other letter
4. Student is sending a description of the project and a summary of his background information which will help the person at the XYZ Corporation respond without duplicating information already collected.
5. Shows that student is already familiar with corporation
6. Student suggests that talking with someone may be helpful. Although this is not always possible, it is a good way to begin a mentor relationship.
7. Student is polite ("Thank you for your . . .") and is not demanding that a response be sent by Friday!
8. Student doesn't ask help for his friend

The following references on energy are representative but not exhaustive. They will provide a starting point to help students begin their research.

ADVANCED AUTOMOTIVE PROPULSION SYSTEMS

American Motors Corporation
Engineering Planning and Technical Information Service
14250 Plymouth Road
Detroit, MI 48232

Chrysler Corporation
Engineering and Product Development
P.O. Box 1919
Detroit, MI 48288

Ford Motor Company
Research and Engineering Center
20000 Rotunda Drive
Dearborn, MI 48121

General Motors Research Laboratories
Mound and 12 Mile Road
Warren MI 48090

Gray, Charles L., Jr. 1981. The Fuel Economy of Light Vehicles. Scientific American May 1981.

Hamilton, William. 1980. Electric Automobiles McGraw-Hill. New York, NY.

Norbye, Jan P. 1978. Modern Diesel Cars. Tab Books. Blue Ridge, PA.

Pierce, John M. 1975. The Fuel Consumption of Automobiles. Scientific American January 1975.

BIOMEDICAL SCIENCES

American Institute of Biological Sciences
1401 Wilson Blvd.
Arlington, VA 22209

Federation of American Societies for Experimental Biology
9650 Rockville Pike
Bethesda, MD 20014

CHEMISTRY

American Chemical Society
1155 16th Street, N.W.
Washington, D.C. 20036

American Institute of Chemical Engineers
345 East 47th Street
New York, NY 10017

Electrochemical Society
10 South Main Street
Pennington, NJ 08534

COAL AND COAL PRODUCTS

National Coal Association
1130 17th Street, N.W.
Washington, D.C. 20036

Office of Technology Assessment. 1979. The Direct Use of Coal: Prospects and Problems of Production and Combustion. OTA. Washington, D.C.

Ohio Mining and Reclamation Association
50 South Young Street
Columbus, OH 43215

Ohio Geological Survey
Fountain Square
Columbus, OH 43224

President's Commission on Coal. 1980. Coal Data Book, Staff Findings, Summary and Recommendations. Washington, D.C.

Slatnik, Eugene R. Editor. 1982. Coal Data: A Reference U.S. GPO. Washington, D.C. Stock No. 061-003-00273-1. 69 p.

ELECTRIC POWER ENGINEERING

EPRI. 1982. Electricity, Today's Technology, Tomorrow's Alternatives. William Kaufmann, Inc. Los Altos, CA. 104 p.

Electric Power Research Institute
Communications Division
P.O. Box 10412
Palo Alto, CA 94303

Fowler, John M. 1975. Appendix 5. Generation, Transmission, and Distribution of Electricity. IN: Energy-Environment Source Book. National Science Teachers Association. Washington, D.C. 280 p.

ENERGY CONSERVATION, CONSUMPTION, AND UTILIZATION

Greene, Richard. Editor. 1982. Process Engineering Conservation. Chemical Engineering McGraw-Hill Publishing Co. New York, NY. 324 p.

Hickok, Floyd. 1979. Your Energy Efficient Home. Prentice-Hall, Inc. Englewood Cliffs, NJ.

Irwin, Nancy. Editor. 1981. A New Prosperity, Building a Sustainable Energy Future. Brick House Publishing. Andover, MA 454 p.

Meckler, Milton. 1980. Energy Conservation in Buildings and Industrial Plants. McGraw-Hill Book Co. New York, NY. 270 p.

Owens-Corning Fiberglas Technical Center
Technical Center
Granville, OH 43023

Thomas, John A.G. Editor. 1977. Energy Analysis. Westview Press. Boulder, CO. 162.

ENERGY CONVERSION

Baillie, Richard C. 1978. Energy Conversion Engineering. Addison-Wesley. Reading, MA. 536 p.

Marshall, E. 1984. The Procrastinator's Power Source. Science April 20, 1984.

Reynolds, William C. 1974. Energy: From Nature to Man. McGraw-Hill New York, NY.

Various authors. various dates. Proceedings of the Annual Intersociety Energy Conversion Engineering Conferences. American Institute of Chemical Engineers.

ENERGY PLANNING AND POLICY

Committee on Nuclear and Alternative Energy Systems. 1979. Energy in Transition: 1985-2000. National Academy of Sciences. W. H. Freeman and Company. San Francisco, CA. 676 p.

Pimental, David. 1979. Food, Energy and Society. John Wiley & Sons, Inc. New York, NY.

Stobaugh, Robert and Daniel Yergin. 1979. Energy Future: Report of the Energy Project of the Harvard Business School. Random House. New York, NY. 356 p.

ENERGY STORAGE

Brockis, J. M. and S. Srinivasan. 1969. Fuel Cells: Their Electrochemistry. McGraw-Hill, New York, NY. 660 p.

Electrochemical Society
10 South Main Street
Pennington, NJ 08534

Electric Power Research Institute
P.O. Box 10412
Palo Alto, CA 94303

Kalhammer, F.R. 1979. Energy Storage Systems. Scientific American December 1979. p. 56.

Post, R.F. and S.F. Post. 1973. Flywheels. Scientific American December 1973. p. 17.

ENGINEERING

American Society of Heating, Refrigeration and
Air Conditioning Engineers
1791 Tullie Circle, N.E.
Atlanta, GA 30329

American Society of Mechanical Engineers
345 Est 47th Street
New York, NY 10017

Hunt, Daniel V. 1982. Handbook of Energy Technology, Trends and Perspectives. Van Nostrand Reinhold Co. New York, NY. 1018 p.

Institute of Electrical and Electronics Engineers
345 East 47th Street
New York, NY 10017

Loftness, William .1978. Energy Handbook. Van Nostrand, New York, NY

Meyers, Robert A. Editor. 1983. Handbook of Energy Technology and Economics. John Wiley & Sons, Inc. New York, NY. 1090 p.

ENVIRONMENTAL SCIENCES (AQUATIC, ATMOSPHERIC, AND TERRESTRIAL)

Broecker, W.S. et. al. 1979. Fate of Fuel Carbon Dioxide and Global Carbon Dioxide Budget. Science (206) October 26, 1979. p. 409.

Fowler, John M. 1975. Energy-Environment Source Book NSTA. Washington, D.C. 280 p.

National Wildlife Federation
1412 Sixteenth Street, N.W.
Washington, D.C. 20036

Odum, Howard T. 1971. Environment, Power and Society.
317 p.

_____. and Elizabeth C. Odum. 1976. Energy Basis for Man
and Nature. McGraw-Hill, New York, NY. 296 p.

Woodwell, George M. 1978. The Carbon Dioxide Question. Scientific
American. January 1978.

ENVIRONMENTAL--SOCIAL ASPECTS OF ENERGY TECHNOLOGIES

Cook, Earl. 1976. Man, Energy, Society. W.H. Freeman,
San Francisco.

Lovins, Amory B. 1977. Soft Energy Paths--Toward a Durable Peace.
Harper Colophon, New York, NY.

Stern, Paul C. and Elliot Aronson, Editors. 1984. Energy Use: The
Human Dimension. W.H. Freeman & Co., New York, NY. 238 p.

FUSION ENERGY and FUSION FUELS

American Nuclear Society
555 North Kensington Ave.
LaGrange Park, IL 60525

Conn, R.W. 1983. The Engineering of Magnetic Fusion Reactors.
Scientific American. October 1983.

Holdren, J.P. 1978. Fusion Energy in Context: Its Fitness for the
Long Term. Science 200(168) April 14, 1978.

Seaborg, Glenn T. and Justin L. Bloom. 1970. Fast Breeder
Reactors. Scientific American 223(5) November 13, 1970.

GENERAL AND GEOSCIENCES

Hubbert, M.King. 1971. The Energy Sources of the Earth.
Scientific American. 224(3) September 1971.

National Academy of Sciences. 1980. Energy in Transition, 1985-
2010. The CONAES Report to Capitol Hill. W.H. Freeman, San
Francisco, CA 1980.

Skinner, Brian F. 1976. Earth Resources, Second Edition.
Prentice-Hall. 330p.

GEOHERMAL ENERGY

Barnea, Joseph. 1972. Geothermal Power. Scientific American 226(1), 1972.

Kruger, Paul and Carol Otte, Editors. 1973. Geothermal Energy. Stanford University Press, Stanford, CA.

White, D. E. and D.L. Williams. 1975. Assessment of Geothermal Resources of the United States. U.S. Geological Survey Circular No. 726.

HEALTH AND SAFETY

Dosimeter Corporation
6106 Interstate Circle
Cincinnati, OH 45242

National Research Council Committee on the Biological Effects of Ionizing Radiation. 1980. The Effects on Populations of Exposure to Low-Level Ionizing Radiation. National Academy Press, Washington, D.C.

Nuclear Medicine Laboratory
Cincinnati General Hospital
Cincinnati, OH 45267

Upton, A.C. 1982. The Biological Effects of Low-Level Ionizing Radiation. Scientific American 246(41) February 1982.

HYDROGEN

Anon. no date. Hydrogen Energy: A Bibliography with Abstracts. Technology Application Center, Publication Section, University of New Mexico, Albuquerque, NM 87131.

Cohen, R. L. and J. H. Wernick. 1981. Hydrogen Storage Materials: Properties and Possibilities. Science 214(1981) p.1081

Gregory, Derek P. The Hydrogen Economy. Scientific American. January 1973, p. 13.

INSTRUMENTATION

See national laboratories under Particle Accelerators.

Instrument Society of America
P.O. Box 12277
Research Triangle Park, NC 27709

ISOTOPE AND RADIATION SOURCE TECHNOLOGY

See national laboratories under Particle Accelerators.

MATERIALS

American Ceramic Society
65 Ceramic Drive
Columbus, OH 43214

American Society of Metals
Metals Park, OH 44073

General Electric R&D Center
Schenectady, NY 12345

Oak Ridge National Laboratories
P.O. Box X
Oak Ridge, TN 37830

NATURAL GAS

American Gas Association
1515 Wilson Blvd.
Arlington, VA 22209

Gas Research Institute
8600 Bryn Mawr Ave.
Chicago, IL 60631

Institute of Gas Technology
3424 South State Street
Chicago, IL 60616

Lawrence, George H. 1977. Gas Industry Outlook Good for 2000. IN: Petroleum 2000, Special Issue of the Oil & Gas Journal, August 1977.

NUCLEAR FUELS, POWER PLANTS and REACTOR TECHNOLOGY

American Nuclear Society
555 N. Kensington Avenue
LaGrange, IL 60525

Atomic Industrial Forum
7101 Wisconsin Avenue
Washington, D.C. 20014

Committee on Nuclear and Alternative Energy Systems. 1979. Energy in Transition: 1985-2000. National Academy of Sciences. W.H. Freeman and Company, San Francisco. 676 p.

Electric Power Research Institute
P.O. Box 10412
Palo Alto, CA 94303

The Ohio State University
Van de Graaf Laboratory
1190 Kinnear Road
Columbus, OH 43212

The Ohio State University
Research Reactor
1298 Kinnear Road
Columbus, OH 43212

Pringle, Laurence. 1979. Nuclear Power. MacMillan, New York, NY.

Weaver, Kenneth F. 1979. The Promise and Peril of Nuclear Energy.
National Geographic April 1979, pp. 459-493.

OIL SHALES AND TAR SANDS

Culbertson, William C. and Janet K. Pitman. 1973. Oil Shale. U.S. Geological Survey Professional Paper No. 820. Washington, D.C. U.S. GPO.

Kraushaar, Jack J. and Robert A. Ristnen. 1984. Shale Oil. In: Energy and Problems of a Technical Society. John Wiley & Sons. New York, NY 516 p.

OTHER SYNTHETIC AND NATURAL FUELS

Bente, Paul F., Jr. 1980. The Bio-Energy Directory. The Bio-Energy Council, 825 A, 1625 Eye Street, N.W., Washington, D.C. 20006.

Jones and Associates, Inc. 1980. Alcohol Fuels from Ohio Farms. Ohio Department of Development, Division of Energy, P.O. Box 1001, Columbus, OH 43216. File No. T184901773. 34 p.

Lipfert, F. W. and J.L. Dugan. 1984. Residential Firewood Use. Science February 17, 1984.

_____. 1984. Residential Firewood Use
in the U.S. Science March 25, 1984.

PARTICLE ACCELERATORS

Argonne National Laboratory
9700 Cass Avenue
Argonne, IL 60439

Brookhaven National Laboratory
Upton, NY 11973

Fermi National Accelerator Laboratory
P.O. Box 500
Batavia, IL 60510

Lawrence Livermore National Laboratory
P.O. Box 808
Livermore, CA 94550

PETROLEUM

American Petroleum Institute
2101 L Street, N. W.
Washington, D.C. 20037

Hall, C.A.S. and C. J. Cleveland. 1981. Petroleum Drilling and Production in the United States: Yield Per Effort and Net Energy Analysis. Science 211, Feb. 6, 1981, p. 576.

Hubbert, M. K. 1971. The Energy Resources of the Earth. Scientific American 224(3) Sept. 1971. (Also in Energy and Power, a Scientific American Book. W.H. Freeman, 1971).

Menard, H. William. 1981. Towards a Rational Strategy for Oil Exploration. Scientific American 244, January 1981, pp. 55-65.

PHYSICS

Bartlett, Albert A. 1978. Forgotten Fundamentals of the Energy Crisis. American Journal of Physics 46(9), Sept., 1978.

Kraushaar, Jack J. and Robert A. Ristinen. 1984. Energy and Problems of a Technical Society. John Wiley & Sons, New York, NY. 516 p.

Priest, Joseph M. 1984. Energy: Principles, Problems, Alternatives, Third Edition. Addison-Wesley Publishing Co., Reading, MA 348 p.

Romer, Robert H. 1976. Energy - An Introduction to Physics. Freeman, San Francisco, CA.

SOLAR ENERGY

Council on Environmental Quality. 1978. Solar Energy: Progress and Promise. GPO Washington, D.C.

Mazria, Edward. 1979. The Passive Solar Energy Book. Rodale Press, Emmaus, PA.

Meinel, Aden B. and Marjorie P. Meinel. 1972. Physics Looks at Solar Energy. Physics Today 25(2).

McPhillips, M. 1982. Passive Solar Homes. Facts on File, Inc. New York, NY. 287 p.

Solar Energy Research Institute
1617 Cole Blvd.
Golden, CO 80401

TIDAL AND WAVE POWER

Gray, L. J. and O.K. Gashus. 1972. Tidal Power. Plenum Press, New York, NY. 1972. 630 p.

Newman, J. N. 1983. "Power from Ocean Waves" Technology Review 86(50), July, 1983.

WIND ENERGY

Cheremisinoff, Nicholas P. 1978. Fundamentals of Wind Energy. Ann Arbor Science Publishers, Ann Arbor, MI. 170 p.

Inglis, David R. 1980. Wind Power and other Energy Technologies. The University of Michigan Press, Ann Arbor, MI.

Justis, C. G. 1978. Winds and Wind System Performance. Franklin Institute, Philadelphia, PA 120 p.



“The Academy is the common meeting ground of the scientific activities of the State.”

About the Academy

The Ohio Academy of Science is a nonprofit membership organization founded in 1891 to stimulate interest in the sciences, to promote research, to improve instruction in the sciences, to disseminate scientific knowledge and to recognize high achievements in attaining these objectives. Anyone interested in science may join. Recognized as the common meeting ground of the scientific activities of the State, the Academy publishes *The Ohio Journal of Science*, promotes youth science opportunities through the Ohio Junior Academy of Science, and conducts an annual meeting with presentations in nearly 20 fields of science. For additional information contact: The Ohio Academy of Science, 445 King Avenue, Columbus, OH 43201 Phone (614) 424-6045.

BEST COPY AVAILABLE